

F-450 4 X 4 ULTRAMEDIC PASS-THROUGH

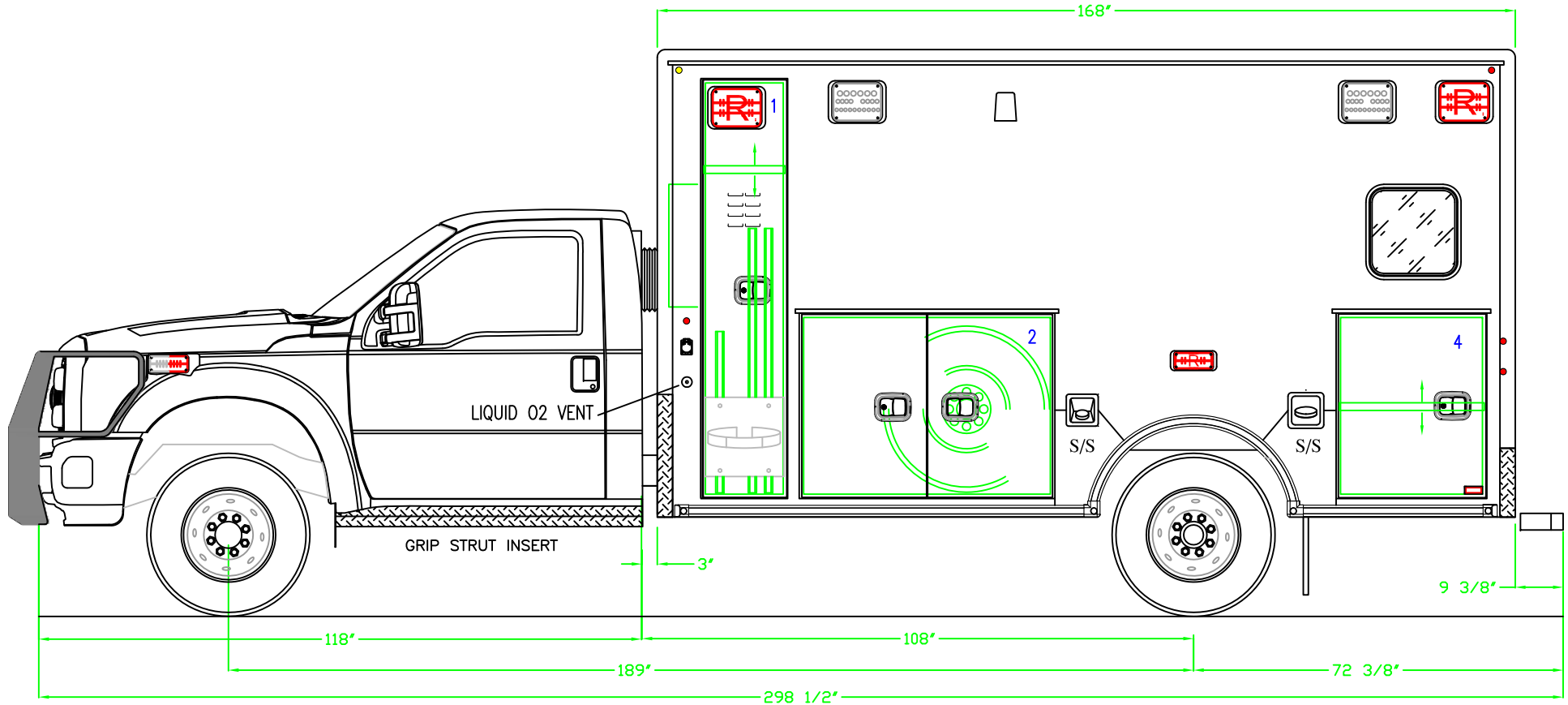



DOOR NO.	INTERIOR DIMENSIONS			NOTES	DOOR NO.	INTERIOR DIMENSIONS			NOTES
	HEIGHT	WIDTH	DEPTH			HEIGHT	WIDTH	DEPTH	
1	81.50"	17.00"	22.00"	(1) ADJ. SHELF, DOOR LOUVERS, O2 STORAGE	4	35.50"	29.50"	21.25"	(1) ADJ. SHELF
2	35.50"	50.00"	21.25"	SPARE TIRE STORAGE	DETAILS ARE CONCEPTUAL ONLY. LAYOUT AND ALL DIMENSIONS ARE APPROXIMATE AND SUBJECT TO MODIFICATION BY DESIGN ENGINEERING.				

PROPRIETARY AND CONFIDENTIAL
THIS INFORMATION CONTAINED IN THIS DRAWING IS THE SOLE PROPERTY OF ROAD RESCUE ANY REPRODUCTION IN PART OR AS A WHOLE WITHOUT THE WRITTEN PERMISSION OF ROAD RESCUE IS PROHIBITED.

Road Rescue 2737 N. FORSYTH RD
WINTER PARK, FL 32792
www.roadrescue.com PHONE 800-932-7077 FAX 800-513-2688
DRAWN BY DATE REVISION 1 REVISION 2 REVISION 3 REVISION 4
RRS 08/10/2016 08/11/2016

STREETSIDE EXTERIOR DETAIL

BID NUMBER
 **1R6222** 

F-450 4 X 4 ULTRAMEDIC PASS-THROUGH

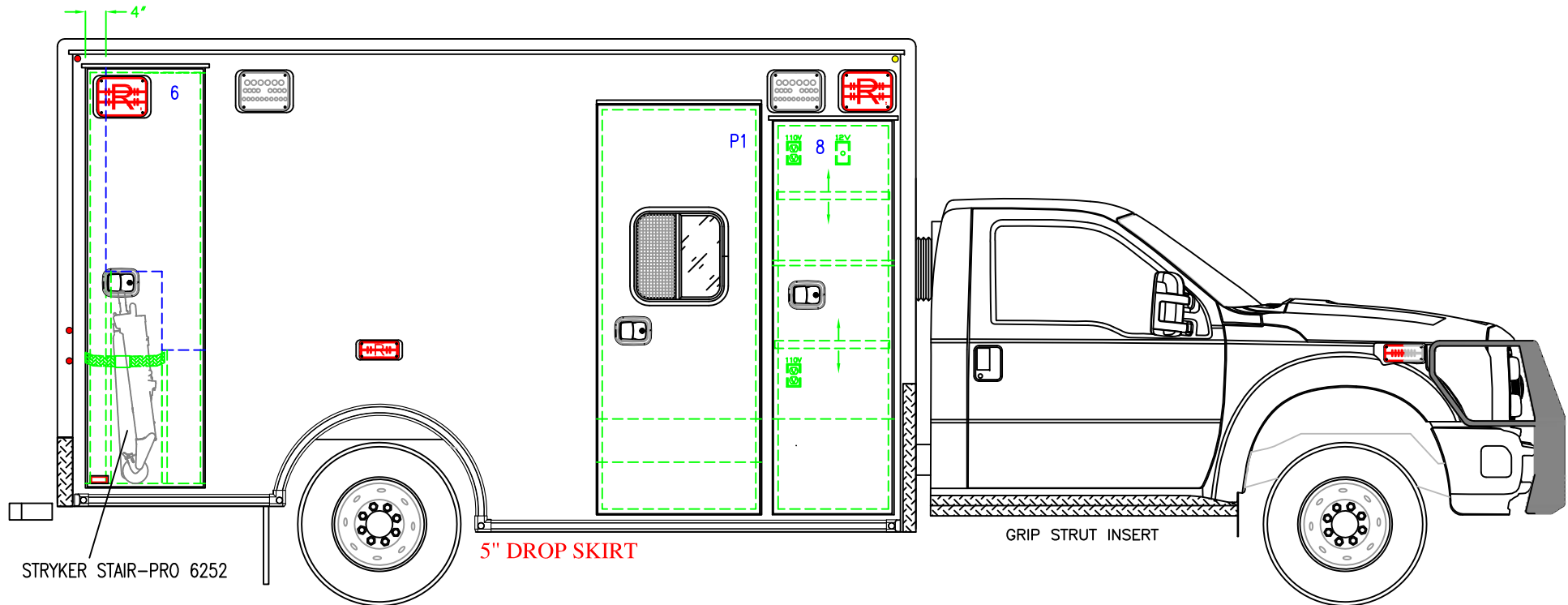



DOOR NO.	INTERIOR DIMENSIONS			NOTES	DOOR NO.	DOOR DIMENSIONS		MISC. NOTES
	HEIGHT	WIDTH	DEPTH			HEIGHT	WIDTH	
6	81.50"	23.50"	22.00"	(1) ADJ. DIVIDER	8	77.00"	23.00"	RIGHT STACK/ALS ACCESS
8.5	16.00"	23.00"	21.00"	BATTERY DRAWER	P1	73.62"	30.06"	SLIDING TINTED WINDOW 18" X 18"
DETAILS ARE CONCEPTUAL ONLY. LAYOUT AND ALL DIMENSIONS ARE APPROXIMATE AND SUBJECT TO MODIFICATION BY DESIGN ENGINEERING.								

PROPRIETARY AND CONFIDENTIAL
THIS INFORMATION CONTAINED IN THIS DRAWING IS THE SOLE PROPERTY OF ROAD RESCUE ANY REPRODUCTION IN PART OR AS A WHOLE WITHOUT THE WRITTEN PERMISSION OF ROAD RESCUE IS PROHIBITED.

Road Rescue 2737 N. FORSYTH RD
WINTER PARK, FL 32792
www.roadrescue.com PHONE 800-932-7077 FAX 800-513-2688
DRAWN BY DATE REVISION 1
RRS 08/10/2016 08/11/2016

CURBSIDE EXTERIOR DETAIL

BID NUMBER
 **1R6222** 

F-450 4 X 4 ULTRAMEDIC PASS-THROUGH

DEALER SIGNATURE 

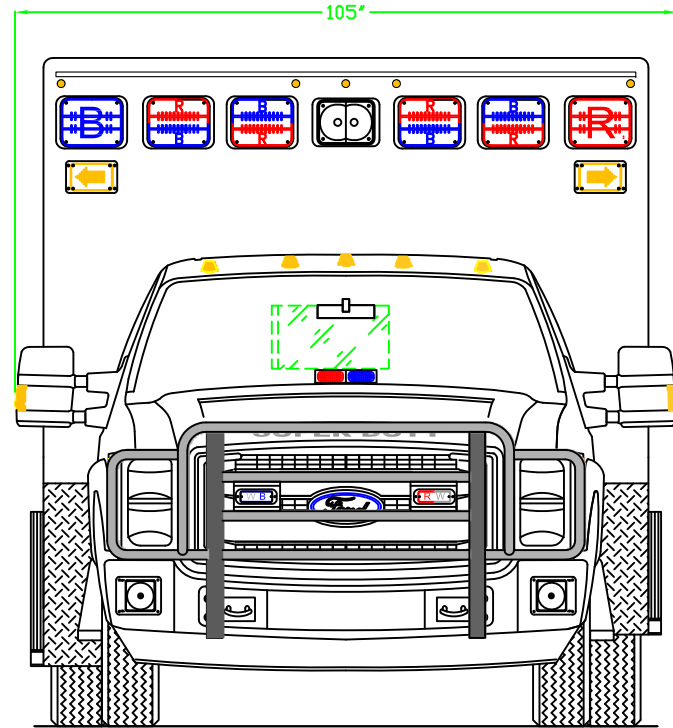
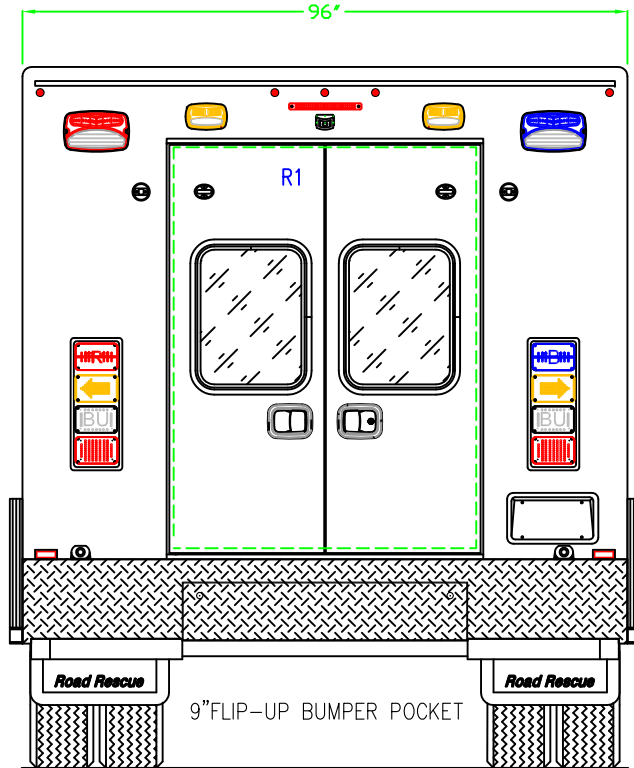

DOOR NO.	CLEAR OPENING		NOTES:
	HEIGHT	WIDTH	
R1	61.62"	50.25"	FIXED TINTED WINDOWS 18" X 24"

DETAILS ARE CONCEPTUAL ONLY.
LAYOUT AND ALL DIMENSIONS ARE APPROXIMATE AND
SUBJECT TO MODIFICATION BY DESIGN ENGINEERING.

PROPRIETARY AND CONFIDENTIAL
THIS INFORMATION CONTAINED IN THIS DRAWING IS THE SOLE PROPERTY OF ROAD RESCUE ANY REPRODUCTION IN PART OR AS A WHOLE WITHOUT THE WRITTEN PERMISSION OF ROAD RESCUE IS PROHIBITED.

Road Rescue 2737 N. FORSYTH RD
WINTER PARK, FL 32792
www.roadrescue.com PHONE 800-932-7077 FAX 800-513-2688

FRONT & REAR EXTERIOR DETAIL

BID NUMBER

DRAWN BY RRS DATE 08/10/2016 REVISION 1 08/11/2016

REVISION 2 REVISION 3 REVISION 4

SHEET 3 OF 13

 **1R6222** 

F-450 4 X 4 ULTRAMEDIC PASS-THROUGH

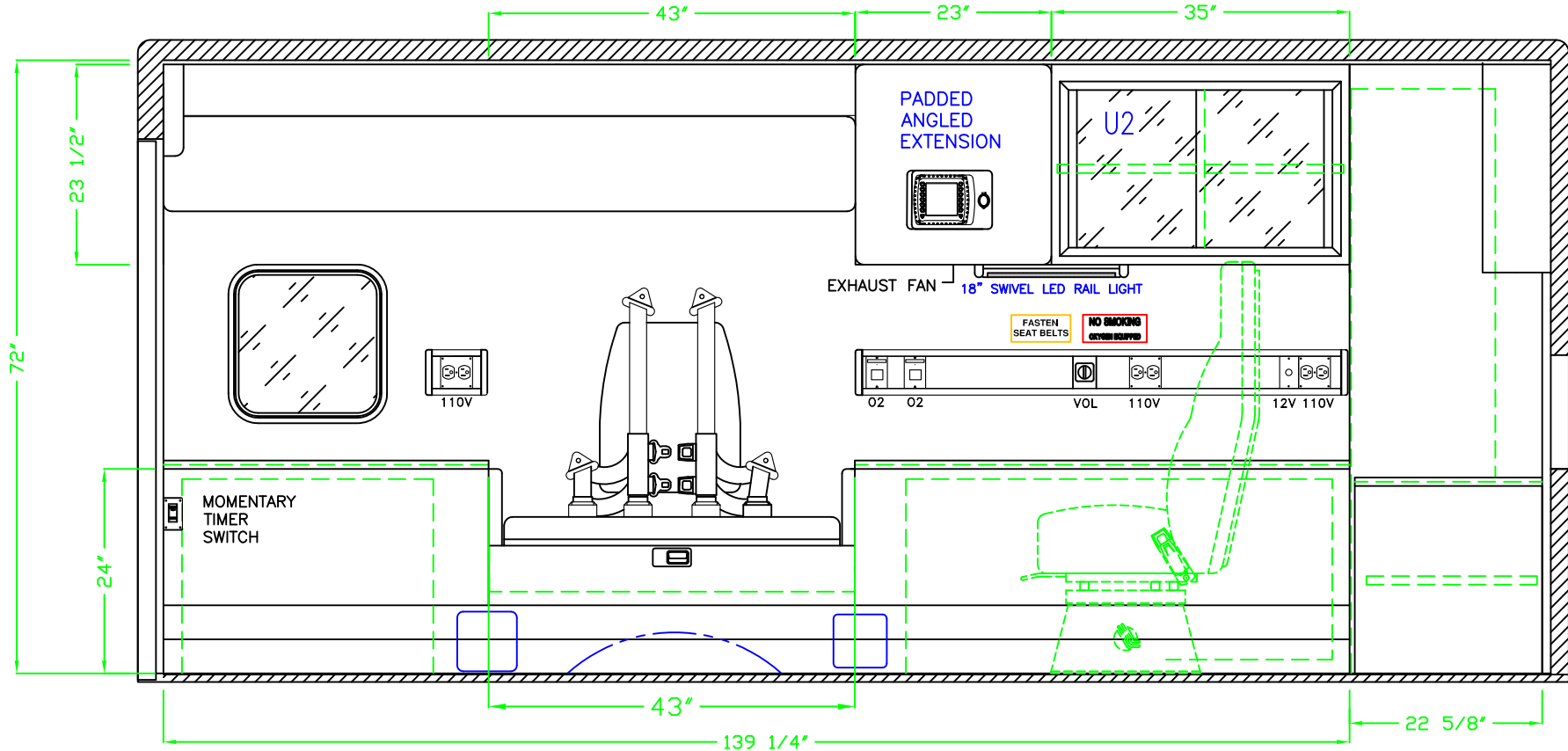

DOOR NO.	INTERIOR DIMENSIONS			NOTES
	HEIGHT	WIDTH	DEPTH	
C1	23.00"	22.50"	15.50"	DOUBLE ALUM. LOCKING DOOR, (1) ADJ. SHELF
L1	23.62"	22.50"	15.50"	DOUBLE ALUM. LOCKING DOOR,
U2	23.50"	34.75"	18.12"	SLIDING PLEX DOORS, (1) ADJ. SHELF, RESTOCK

DETAILS ARE CONCEPTUAL ONLY.
LAYOUT AND ALL DIMENSIONS ARE APPROXIMATE AND
SUBJECT TO MODIFICATION BY DESIGN ENGINEERING.

PROPRIETARY AND CONFIDENTIAL
THIS INFORMATION CONTAINED IN THIS DRAWING IS THE SOLE PROPERTY OF ROAD RESCUE ANY REPRODUCTION IN PART OR AS A WHOLE WITHOUT THE WRITTEN PERMISSION OF ROAD RESCUE IS PROHIBITED.

F-450 4 X 4 ULTRAMEDIC PASS-THROUGH

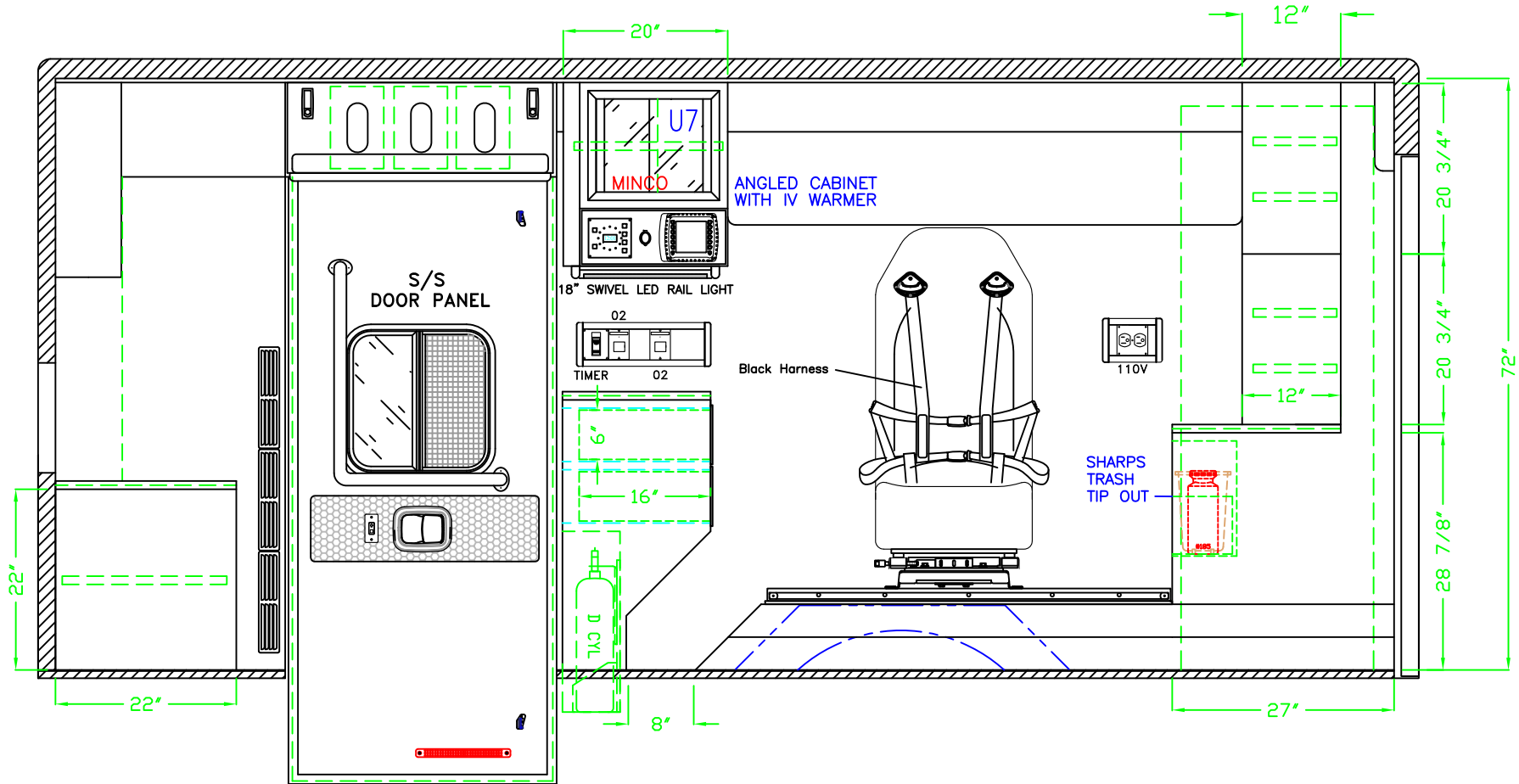

DOOR NO.	INTERIOR DIMENSIONS			MISC. NOTES
	HEIGHT	WIDTH	DEPTH	
U7	20.00"	20.00"		SLIDING PLEX DOORS, (1) ADJ. SHELF

NOTES:

DETAILS ARE CONCEPTUAL ONLY.
LAYOUT AND ALL DIMENSIONS ARE APPROXIMATE AND
SUBJECT TO MODIFICATION BY DESIGN ENGINEERING.

PROPRIETARY AND CONFIDENTIAL
THIS INFORMATION CONTAINED IN THIS DRAWING IS THE SOLE PROPERTY OF ROAD RESCUE ANY REPRODUCTION IN PART OR AS A WHOLE WITHOUT THE WRITTEN PERMISSION OF ROAD RESCUE IS PROHIBITED.

CURBSIDE INTERIOR DETAIL

F-450 4 X 4 ULTRAMEDIC PASS-THROUGH

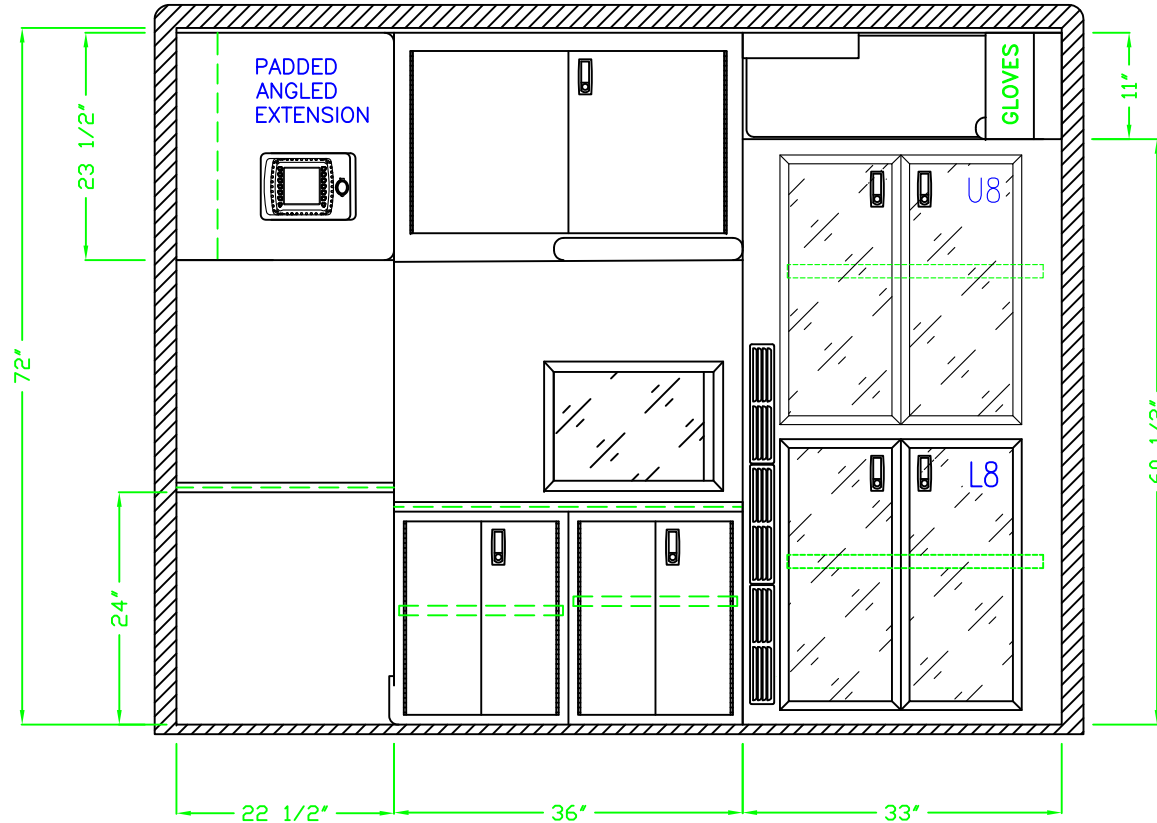

DOOR NO.	INTERIOR DIMENSIONS			NOTES
	HEIGHT	WIDTH	DEPTH	
U8	30.00"	28.00"	20.00"	DOUBLE PLEX DOORS, (1) ADJ. SHELVES
L8	30.00"	28.00"	20.00"	DOUBLE PLEX DOORS, (1) ADJ. SHELVES

NOTES:

DETAILS ARE CONCEPTUAL ONLY.
LAYOUT AND ALL DIMENSIONS ARE APPROXIMATE AND
SUBJECT TO MODIFICATION BY DESIGN ENGINEERING.

PROPRIETARY AND CONFIDENTIAL
THIS INFORMATION CONTAINED IN THIS DRAWING IS THE SOLE PROPERTY OF ROAD RESCUE ANY REPRODUCTION IN PART OR AS A WHOLE WITHOUT THE WRITTEN PERMISSION OF ROAD RESCUE IS PROHIBITED.

FRONT INTERIOR DETAIL

F-450 4 X 4 ULTRAMEDIC PASS-THROUGH

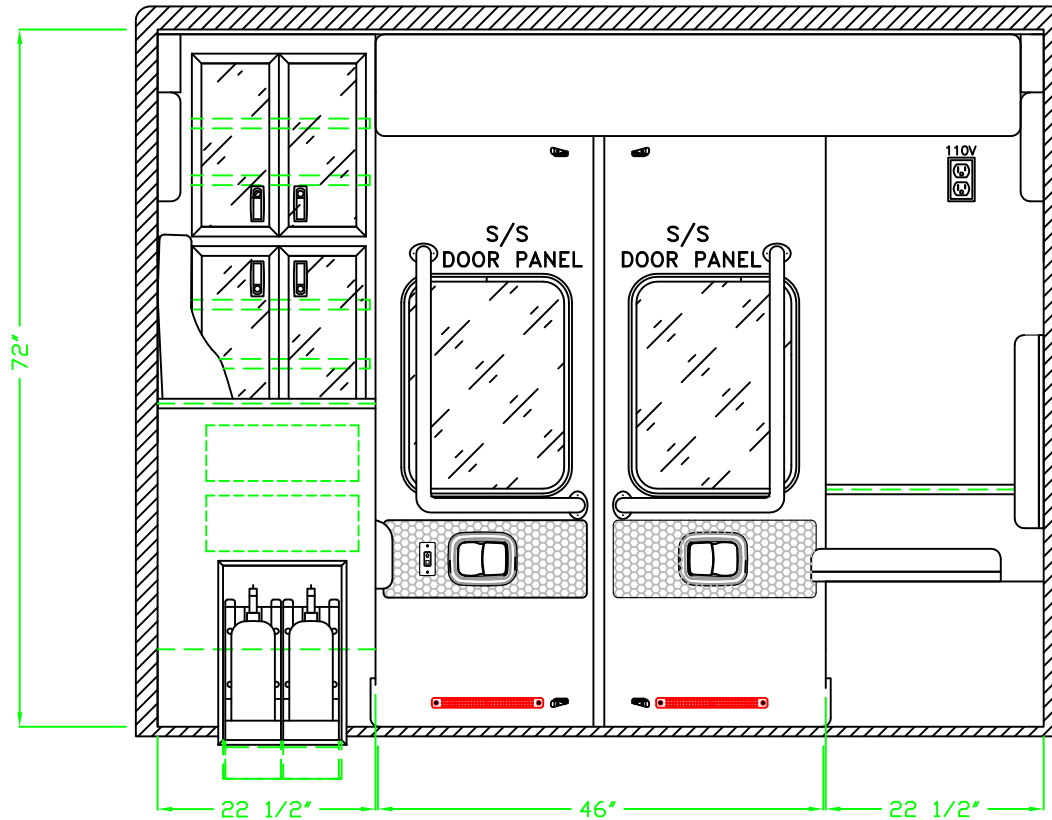

NOTES:

NOTES:

DETAILS ARE CONCEPTUAL ONLY.
LAYOUT AND ALL DIMENSIONS ARE APPROXIMATE AND
SUBJECT TO MODIFICATION BY DESIGN ENGINEERING.

PROPRIETARY AND
CONFIDENTIAL
THIS INFORMATION
CONTAINED IN THIS
DRAWING IS THE SOLE
PROPERTY OF ROAD
RESCUE ANY
REPRODUCTION IN PART
OR AS A WHOLE
WITHOUT THE WRITTEN
PERMISSION OF ROAD
RESCUE IS PROHIBITED.

REAR INTERIOR DETAIL

BID NUMBER

 **1R6222** 

SHEET 7 OF 13



Road Rescue
AN ALLIED SPECIALTY VEHICLE COMPANY
In Service for Life

F-450 4 X 4 ULTRAMEDIC PASS-THROUGH

DEALER SIGNATURE 

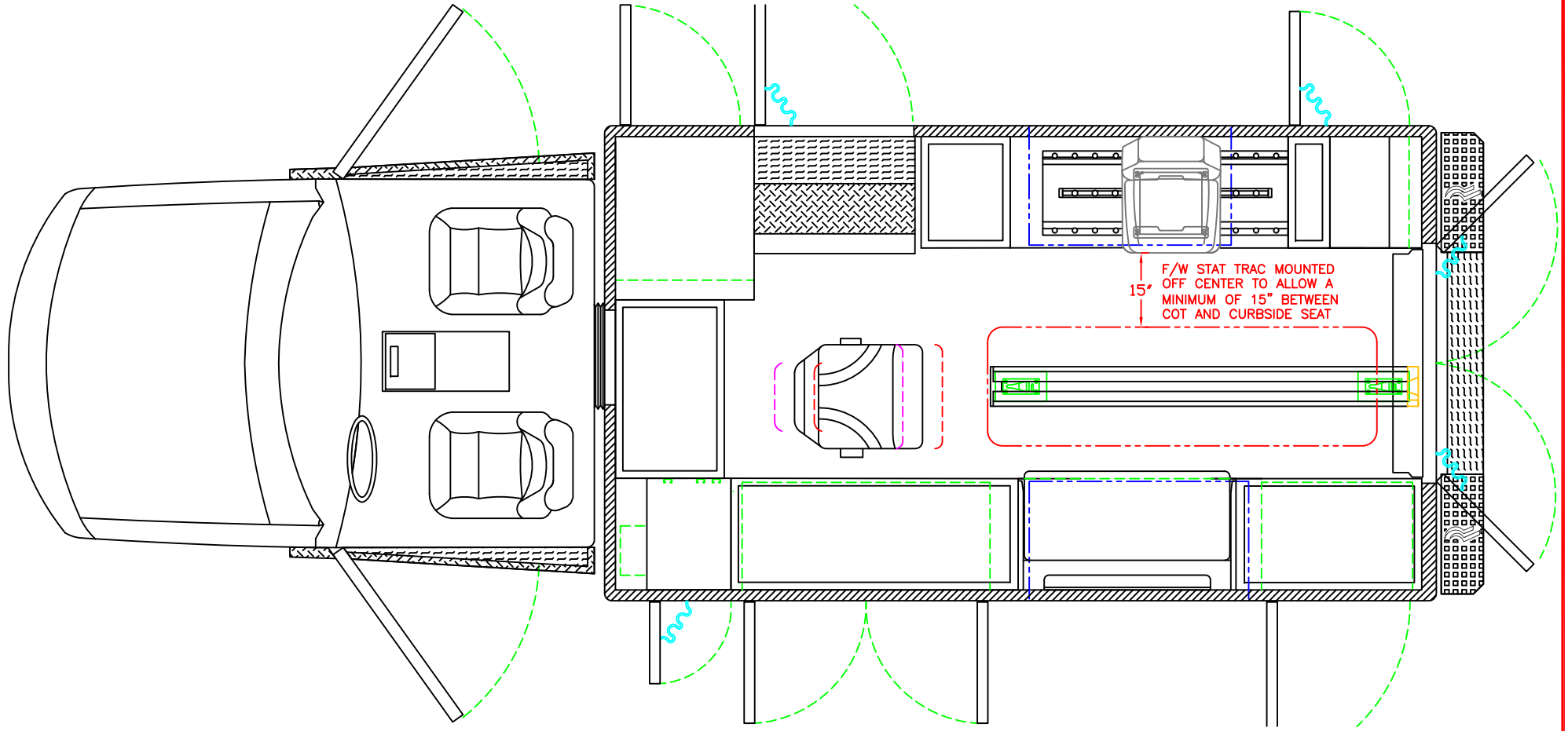

NOTES:



NOTES:

DETAILS ARE CONCEPTUAL ONLY.
 LAYOUT AND ALL DIMENSIONS ARE APPROXIMATE AND
 SUBJECT TO MODIFICATION BY DESIGN ENGINEERING.

PROPRIETARY AND
 CONFIDENTIAL
 THIS INFORMATION
 CONTAINED IN THIS
 DRAWING IS THE SOLE
 PROPERTY OF ROAD
 RESCUE ANY
 REPRODUCTION IN PART
 OR AS A WHOLE
 WITHOUT THE WRITTEN
 PERMISSION OF ROAD
 RESCUE IS PROHIBITED.

Road Rescue 2737 N. FORSYTH RD
 WINTER PARK, FL 32792
 www.roadrescue.com PHONE 800-932-7077 FAX 800-513-2688
 DRAWN BY DATE REVISION 1 REVISION 2 REVISION 3 REVISION 4
 RRS 08/10/2016 08/11/2016

OVERHEAD FLOOR DETAIL

BID NUMBER
 **1R6222** 

SHEET 8 OF 13

F-450 4 X 4 ULTRAMEDIC PASS-THROUGH

CUSTOM LIGHT AND
IV HANGER LOCATIONS

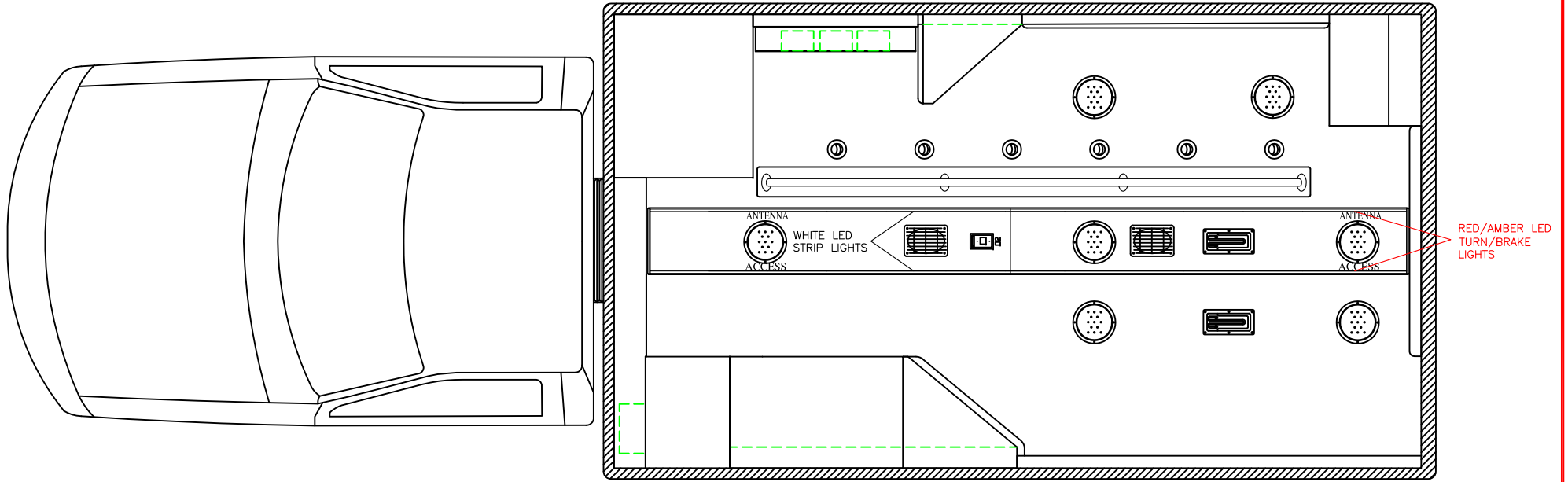

NOTES:



NOTES:

DETAILS ARE CONCEPTUAL ONLY.
LAYOUT AND ALL DIMENSIONS ARE APPROXIMATE AND
SUBJECT TO MODIFICATION BY DESIGN ENGINEERING.

PROPRIETARY AND
CONFIDENTIAL
THIS INFORMATION
CONTAINED IN THIS
DRAWING IS THE SOLE
PROPERTY OF ROAD
RESCUE ANY
REPRODUCTION IN PART
OR AS A WHOLE
WITHOUT THE WRITTEN
PERMISSION OF ROAD
RESCUE IS PROHIBITED.

Road Rescue 2737 N. FORSYTH RD
WINTER PARK, FL 32792
www.roadrescue.com PHONE 800-932-7077 FAX 800-513-2688

OVERHEAD CEILING DETAIL

BID NUMBER
 **1R6222** 

DRAWN BY: RRS DATE: 08/10/2016 REVISION 1: 08/11/2016 REVISION 2: REVISION 3: REVISION 4: SHEET 9 OF 13

F-450 4 X 4 ULTRAMEDIC PASS-THROUGH

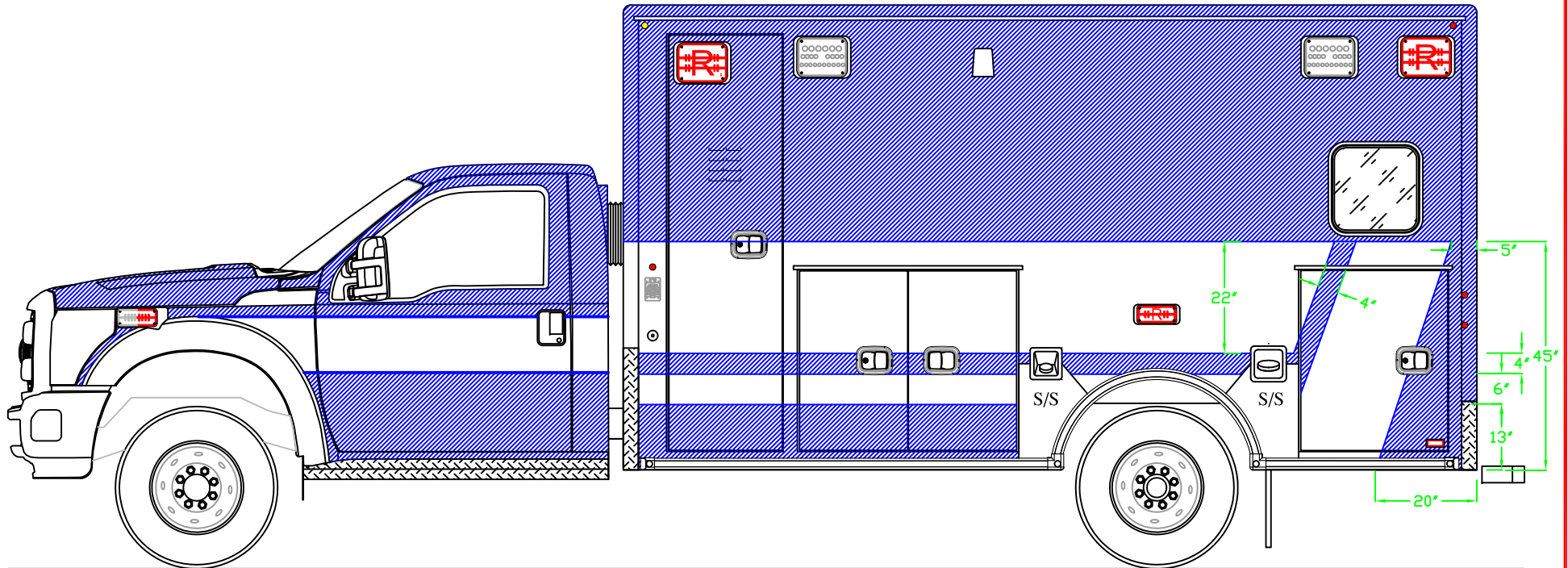

REFERENCE #1R5195

DETAILS ARE CONCEPTUAL ONLY.
LAYOUT AND ALL DIMENSIONS ARE APPROXIMATE AND
SUBJECT TO MODIFICATION BY DESIGN ENGINEERING.

PROPRIETARY AND
CONFIDENTIAL
THIS INFORMATION
CONTAINED IN THIS
DRAWING IS THE SOLE
PROPERTY OF ROAD
RESCUE ANY
REPRODUCTION IN PART
OR AS A WHOLE
WITHOUT THE WRITTEN
PERMISSION OF ROAD
RESCUE IS PROHIBITED.

Road Rescue 2737 N. FORSYTH RD
WINTER PARK, FL 32792
www.roadrescue.com PHONE 800-932-7077 FAX 800-513-2688
DRAWN BY DATE REVISION 1 REVISION 2 REVISION 3 REVISION 4
RRS 08/10/2016 08/11/2016

STREETSIDE GRAPHICS

BID NUMBER

1R6222

F-450 4 X 4 ULTRAMEDIC PASS-THROUGH

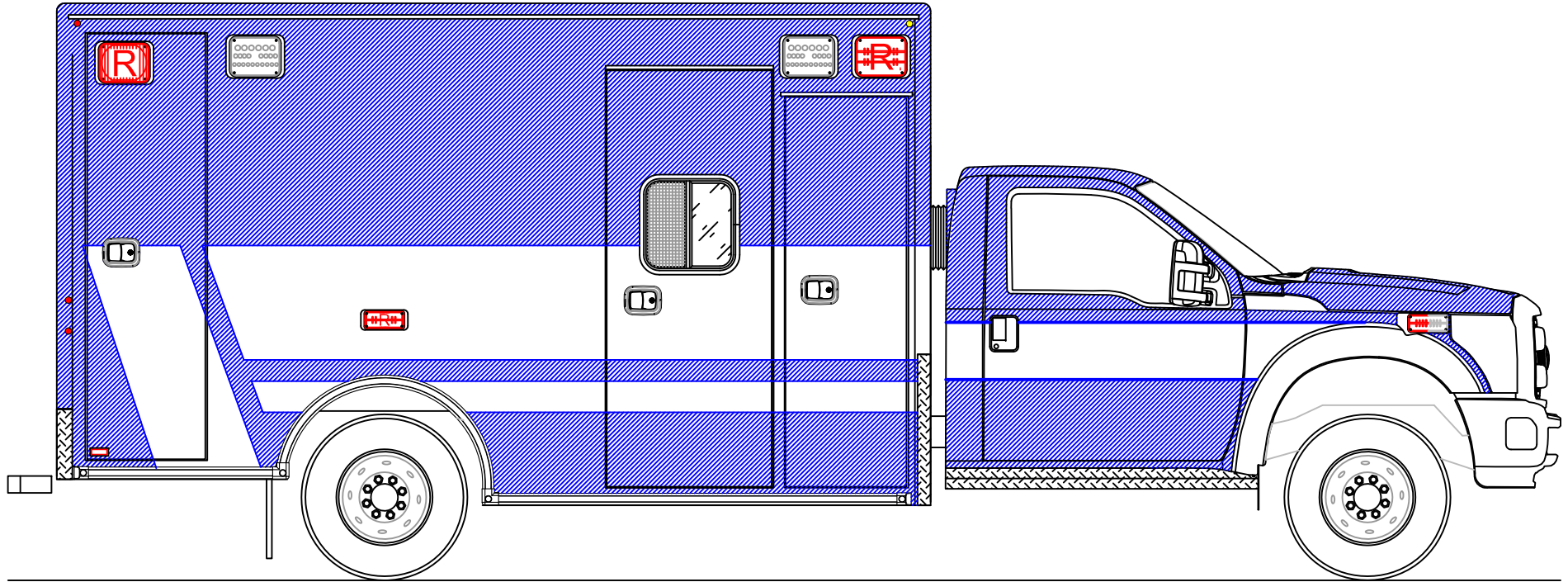

DETAILS ARE CONCEPTUAL ONLY.
LAYOUT AND ALL DIMENSIONS ARE APPROXIMATE AND
SUBJECT TO MODIFICATION BY DESIGN ENGINEERING.

PROPRIETARY AND
CONFIDENTIAL
THIS INFORMATION
CONTAINED IN THIS
DRAWING IS THE SOLE
PROPERTY OF ROAD
RESCUE ANY
REPRODUCTION IN PART
OR AS A WHOLE
WITHOUT THE WRITTEN
PERMISSION OF ROAD
RESCUE IS PROHIBITED.

Road Rescue 2737 N. FORSYTH RD
WINTER PARK, FL 32792
www.roadrescue.com PHONE 800-932-7077 FAX 800-513-2688

CURBSIDE GRAPHICS

BID NUMBER

DRAWN BY RRS	DATE 08/10/2016	REVISION 1 08/11/2016	REVISION 2	REVISION 3	REVISION 4
-----------------	--------------------	--------------------------	------------	------------	------------

SHEET 11 OF 13

 **1R6222** 

F-450 4 X 4 ULTRAMEDIC PASS-THROUGH

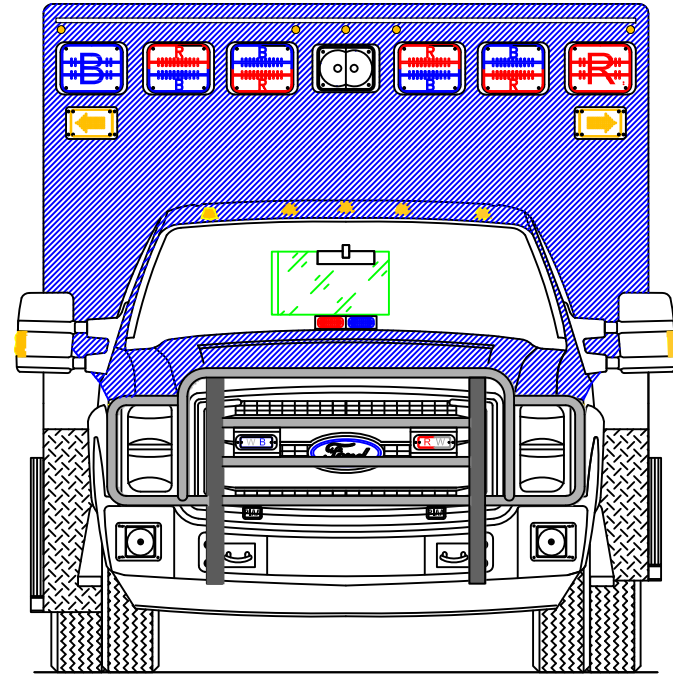
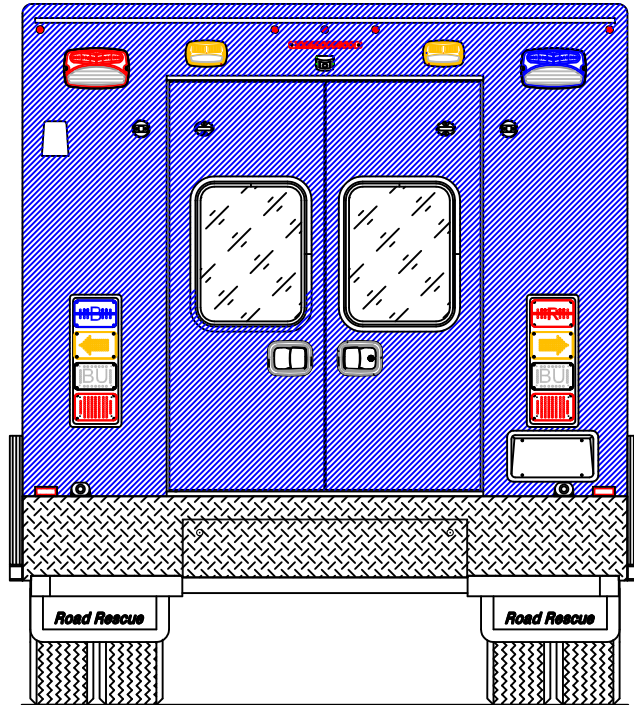

DETAILS ARE CONCEPTUAL ONLY.
LAYOUT AND ALL DIMENSIONS ARE APPROXIMATE AND
SUBJECT TO MODIFICATION BY DESIGN ENGINEERING.

PROPRIETARY AND
CONFIDENTIAL
THIS INFORMATION
CONTAINED IN THIS
DRAWING IS THE SOLE
PROPERTY OF ROAD
RESCUE ANY
REPRODUCTION IN PART
OR AS A WHOLE
WITHOUT THE WRITTEN
PERMISSION OF ROAD
RESCUE IS PROHIBITED.

Road Rescue 2737 N. FORSYTH RD
WINTER PARK, FL 32792
www.roadrescue.com PHONE 800-932-7077 FAX 800-513-2688

FRONT & REAR GRAPHICS

BID NUMBER

DRAWN BY RRS	DATE 08/10/2016	REVISION 1 08/11/2016	REVISION 2	REVISION 3	REVISION 4
-----------------	--------------------	--------------------------	------------	------------	------------

SHEET 12 OF 13

 **1R6222** 

CUSTOM CONSOLE F-450 ULTRAMEDIC

SMART DISPLAY UV700

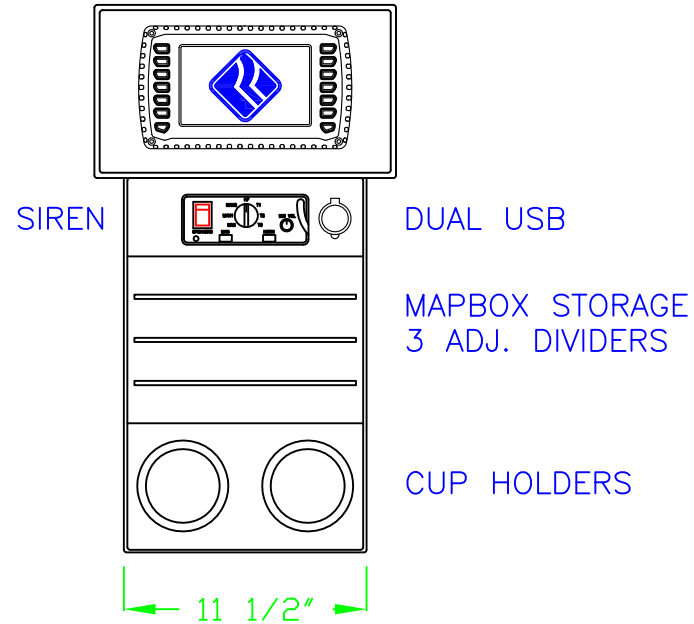
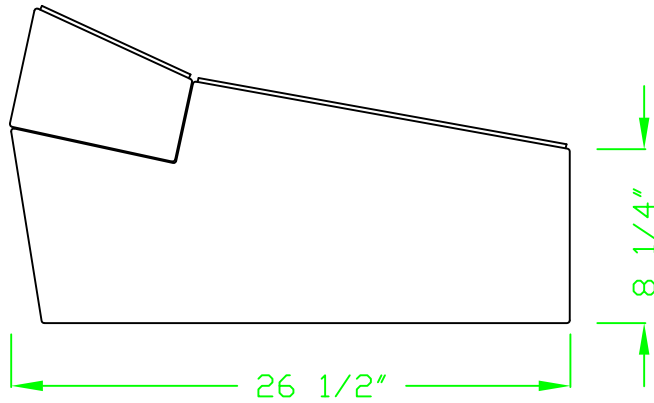

REFERENCE
#1R5195

PROPRIETARY AND
CONFIDENTIAL
THIS INFORMATION
CONTAINED IN THIS
DRAWING IS THE SOLE
PROPERTY OF ROAD
RESCUE ANY
REPRODUCTION IN PART
OR AS A WHOLE
WITHOUT THE WRITTEN
PERMISSION OF ROAD
RESCUE IS PROHIBITED.

DETAILS ARE CONCEPTUAL ONLY. LAYOUT AND ALL DIMENSIONS ARE APPROXIMATE AND SUBJECT TO MODIFICATION BY DESIGN ENGINEERING.

Road Rescue 2737 N. FORSYTH ROAD
WINTER PARK, FL 32792
www.roadrescue.com PHONE 800-932-7077 FAX 800-513-2688

CONSOLE CONFIGURATION

BID NUMBER

DRAWN BY	DATE	REVISION 1	REVISION 2	REVISION 3	SCALE NONE	SHEET 1 OF 1
----------	------	------------	------------	------------	---------------	--------------

