

F-450 4 X 4 ULTRAMEDIC PASS-THROUGH

DO NOT CUT HOLES FOR COMPARTMENT LIGHTING

FL - INDICATES A FULL HEIGHT KINEQUIP FLEXIBLE LIGHTING STRIP

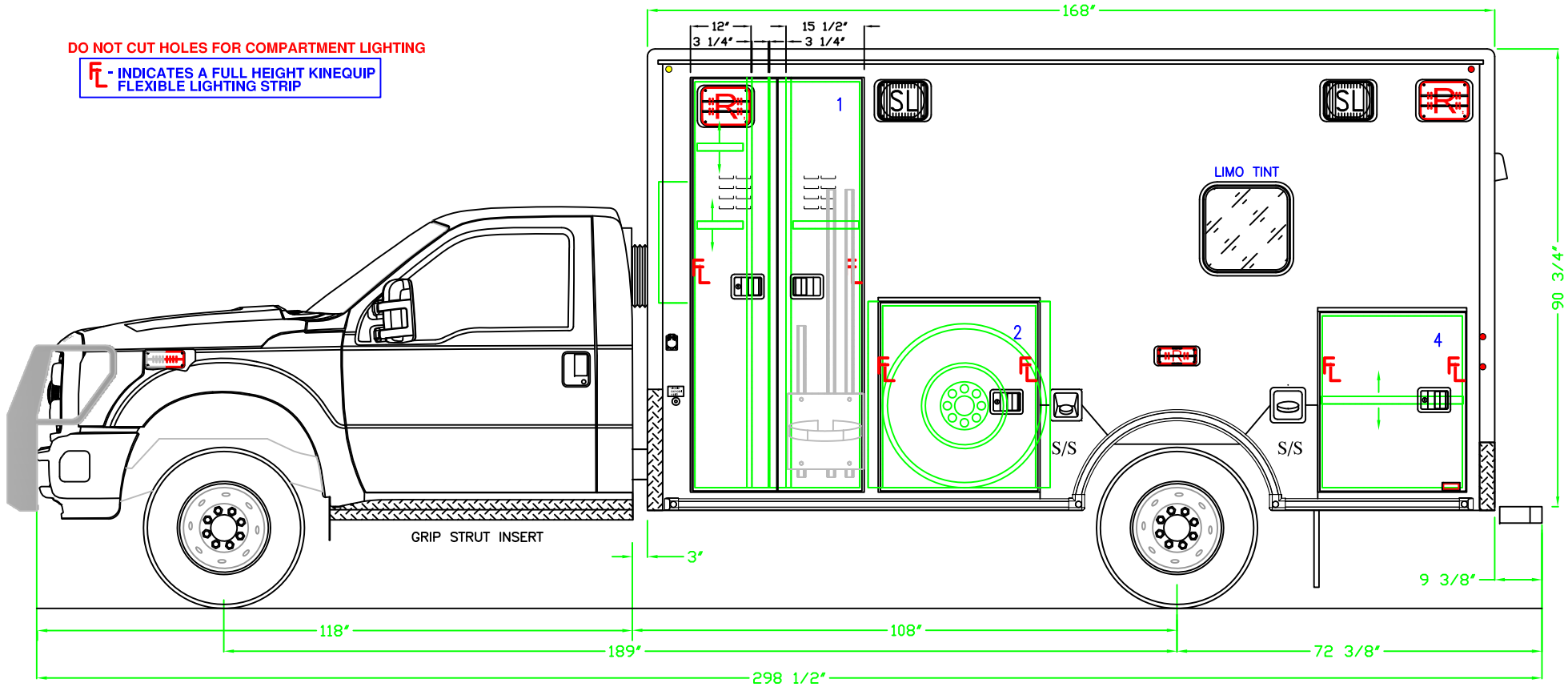

DOOR NO.	INTERIOR DIMENSIONS			NOTES
	HEIGHT	WIDTH	DEPTH	
1	81.50"	34.75"	22.00"	(3) DIVIDERS, (2) ADJ. SHELVES, (1) FIXED SHELF
2	37.50"	32.38"	21.25"	SPARE TIRE STORAGE
4	35.50"	29.50"	21.25"	(1) ADJ. SHELF

DETAILS ARE CONCEPTUAL ONLY.
LAYOUT AND ALL DIMENSIONS ARE APPROXIMATE AND
SUBJECT TO MODIFICATION BY DESIGN ENGINEERING.



PROPRIETARY AND CONFIDENTIAL
THIS INFORMATION CONTAINED IN THIS DRAWING IS THE SOLE PROPERTY OF ROAD RESCUE ANY REPRODUCTION IN PART OR AS A WHOLE WITHOUT THE WRITTEN PERMISSION OF ROAD RESCUE IS PROHIBITED.

Road Rescue 2737 N. FORSYTH RD
WINTER PARK, FL 32792
www.roadrescue.com PHONE 800-932-7077 FAX 800-513-2688

STREETSIDE EXTERIOR DETAIL

BID NUMBER

DRAWN BY RRS DATE 04/15/2015 REVISION 1 05/12/2015 REVISION 2 05/14/2015 REVISION 3 SCALE SHEET 1 OF 12

 **1R5195** 

F-450 4 X 4 ULTRAMEDIC PASS-THROUGH

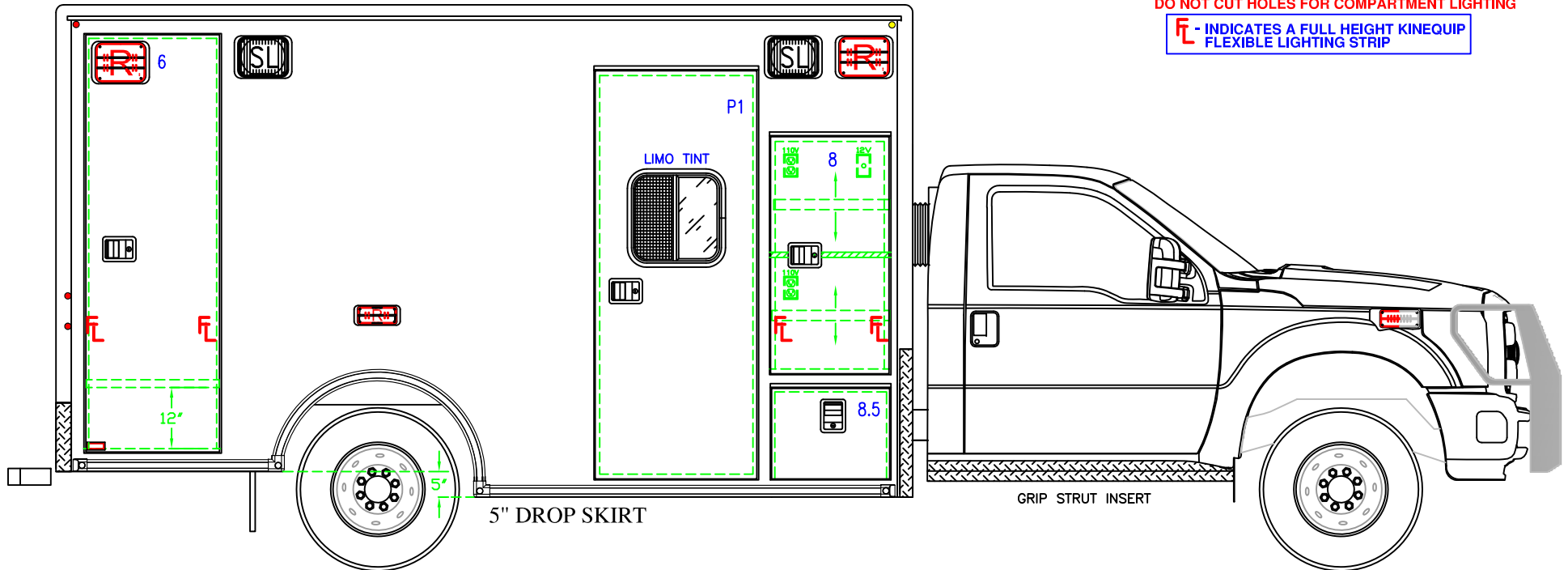

DO NOT CUT HOLES FOR COMPARTMENT LIGHTING

F - INDICATES A FULL HEIGHT KINEQUIP FLEXIBLE LIGHTING STRIP

DOOR NO.	INTERIOR DIMENSIONS			NOTES	DOOR NO.	DOOR JAM OPENING		MISC. NOTES
	HEIGHT	WIDTH	DEPTH			HEIGHT	WIDTH	
6	81.50"	26.75"	21.25"	FULL WIDTH FIXED SHELF	8	45.31"	22.00"	RIGHT STACK/ALS ACCESS
					P1	76.62"	30.06"	SLIDING LIMO TINTED WINDOW 18" X 18"
8.5	17.50"	22.00"	21.00"	BATTERY DRAWER	DETAILS ARE CONCEPTUAL ONLY. LAYOUT AND ALL DIMENSIONS ARE APPROXIMATE AND SUBJECT TO MODIFICATION BY DESIGN ENGINEERING.			

PROPRIETARY AND CONFIDENTIAL
THIS INFORMATION CONTAINED IN THIS DRAWING IS THE SOLE PROPERTY OF ROAD RESCUE ANY REPRODUCTION IN PART OR AS A WHOLE WITHOUT THE WRITTEN PERMISSION OF ROAD RESCUE IS PROHIBITED.

Road Rescue 2737 N. FORSYTH RD
WINTER PARK, FL 32792
www.roadrescue.com PHONE 800-932-7077 FAX 800-513-2688

CURBSIDE EXTERIOR DETAIL

BID NUMBER
1R5195

DRAWN BY: RRS DATE: 04/15/2015 REVISION 1: 05/12/2015 REVISION 2: 05/14/2015 REVISION 3: SCALE: SHEET 2 OF 12

F-450 4 X 4 ULTRAMEDIC PASS-THROUGH

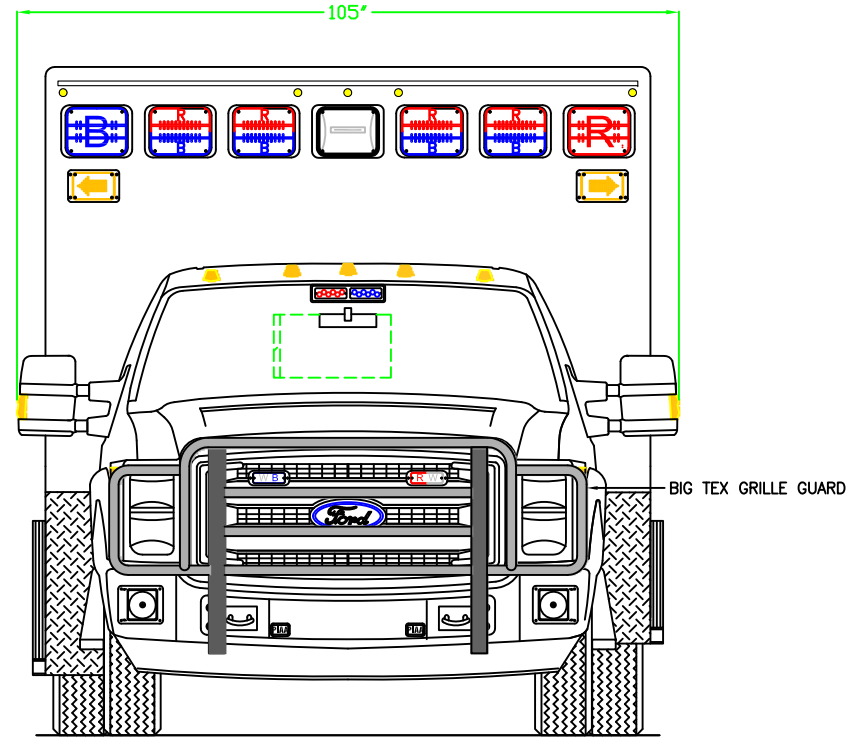
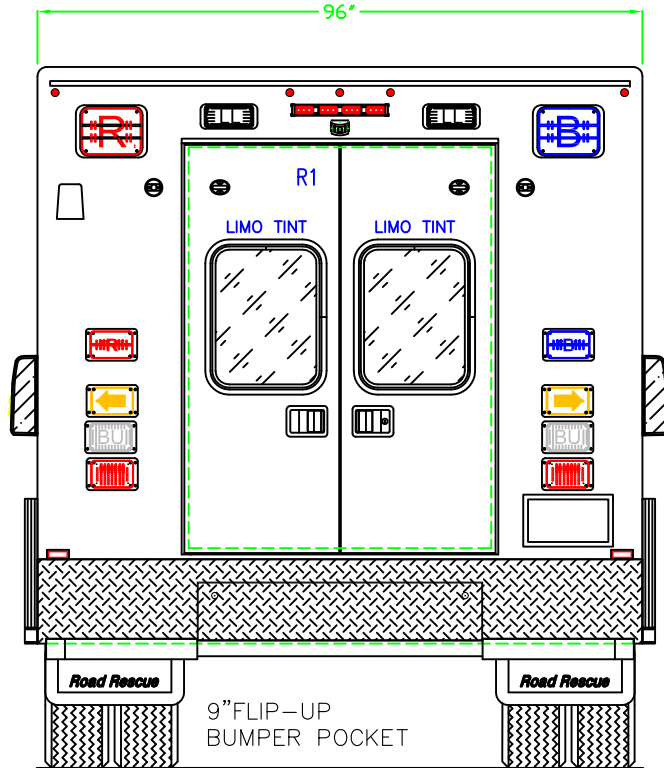

DOOR NO.	CLEAR OPENING		NOTES
	HEIGHT	WIDTH	
R1	61.62"	50.25"	FIXED LIMO TINTED WINDOWS 18" X 24"

NOTES:

NOTES:

DETAILS ARE CONCEPTUAL ONLY.
LAYOUT AND ALL DIMENSIONS ARE APPROXIMATE AND
SUBJECT TO MODIFICATION BY DESIGN ENGINEERING.

PROPRIETARY AND CONFIDENTIAL
THIS INFORMATION CONTAINED IN THIS DRAWING IS THE SOLE PROPERTY OF ROAD RESCUE ANY REPRODUCTION IN PART OR AS A WHOLE WITHOUT THE WRITTEN PERMISSION OF ROAD RESCUE IS PROHIBITED.

Road Rescue 2737 N. FORSYTH RD
WINTER PARK, FL 32792

FRONT & REAR EXTERIOR DETAIL

BID NUMBER
1R5195

www.roadrescue.com	PHONE 800-932-7077	FAX 800-513-2688	REVISION 1	REVISION 2	REVISION 3	SCALE	SHEET 3 OF 12
DRAWN BY RRS	DATE 04/15/2015		05/12/2015	05/14/2015			

F-450 4 X 4 ULTRAMEDIC PASS-THROUGH

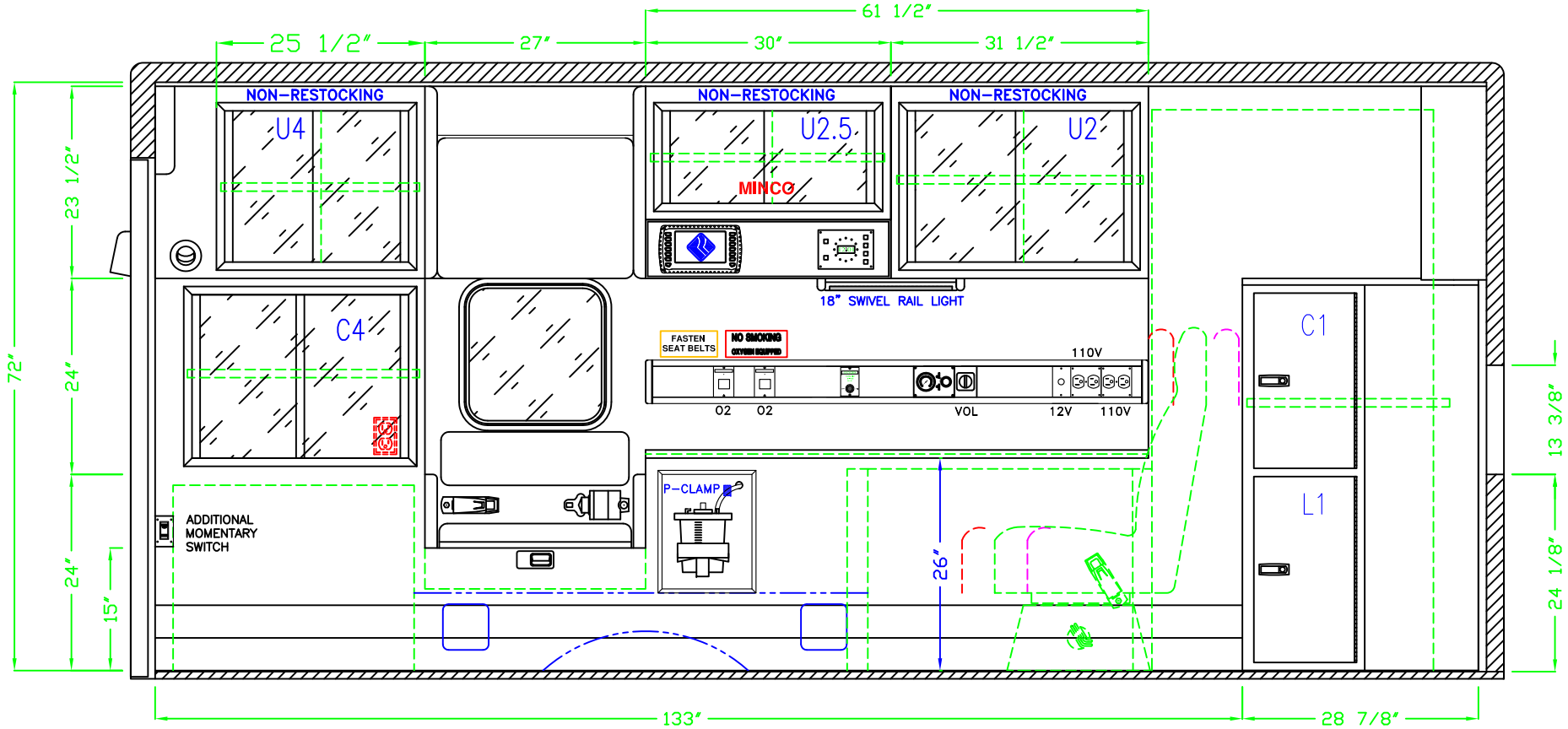



DOOR NO.	INTERIOR DIMENSIONS			NOTES	DOOR NO.	INTERIOR DIMENSIONS			MISC. NOTES
	HEIGHT	WIDTH	DEPTH			HEIGHT	WIDTH	DEPTH	
C1	23.00"	28.50"	15.50"	SINGLE ALUM. DOOR, (1) ADJ. SHELF	U4	23.50"	25.50"	18.12"	SLIDING PLEX DOORS, (1) ADJ. SHELF
L1	23.62"	28.50"	15.50"	SINGLE ALUM. DOOR	C4	24.00"	29.50"	22.00"	SLIDING PLEX DOORS, (1) ADJ. SHELF
U2	23.50"	31.25"	18.12"	SLIDING PLEX DOORS, (1) ADJ. SHELF	DETAILS ARE CONCEPTUAL ONLY. LAYOUT AND ALL DIMENSIONS ARE APPROXIMATE AND SUBJECT TO MODIFICATION BY DESIGN ENGINEERING.				
U2.5	16.00"	29.75"	18.12"	SLIDING PLEX DOORS, (1) ADJ. SHELF					

PROPRIETARY AND CONFIDENTIAL
THIS INFORMATION CONTAINED IN THIS DRAWING IS THE SOLE PROPERTY OF ROAD RESCUE ANY REPRODUCTION IN PART OR AS A WHOLE WITHOUT THE WRITTEN PERMISSION OF ROAD RESCUE IS PROHIBITED.

Road Rescue 2737 N. FORSYTH RD
WINTER PARK, FL 32792
www.roadrescue.com PHONE 800-932-7077 FAX 800-513-2688

STREETSIDE INTERIOR DETAIL

BID NUMBER
 **1R5195** 

DRAWN BY RRS DATE 04/15/2015 REVISION 1 05/12/2015 REVISION 2 05/14/2015 REVISION 3 SCALE SHEET 4 OF 12



Road Rescue
AN ALLIED SPECIALTY VEHICLE COMPANY
In Service for Life

F-450 4 X 4 ULTRAMEDIC PASS-THROUGH

DEALER SIGNATURE	
------------------	--

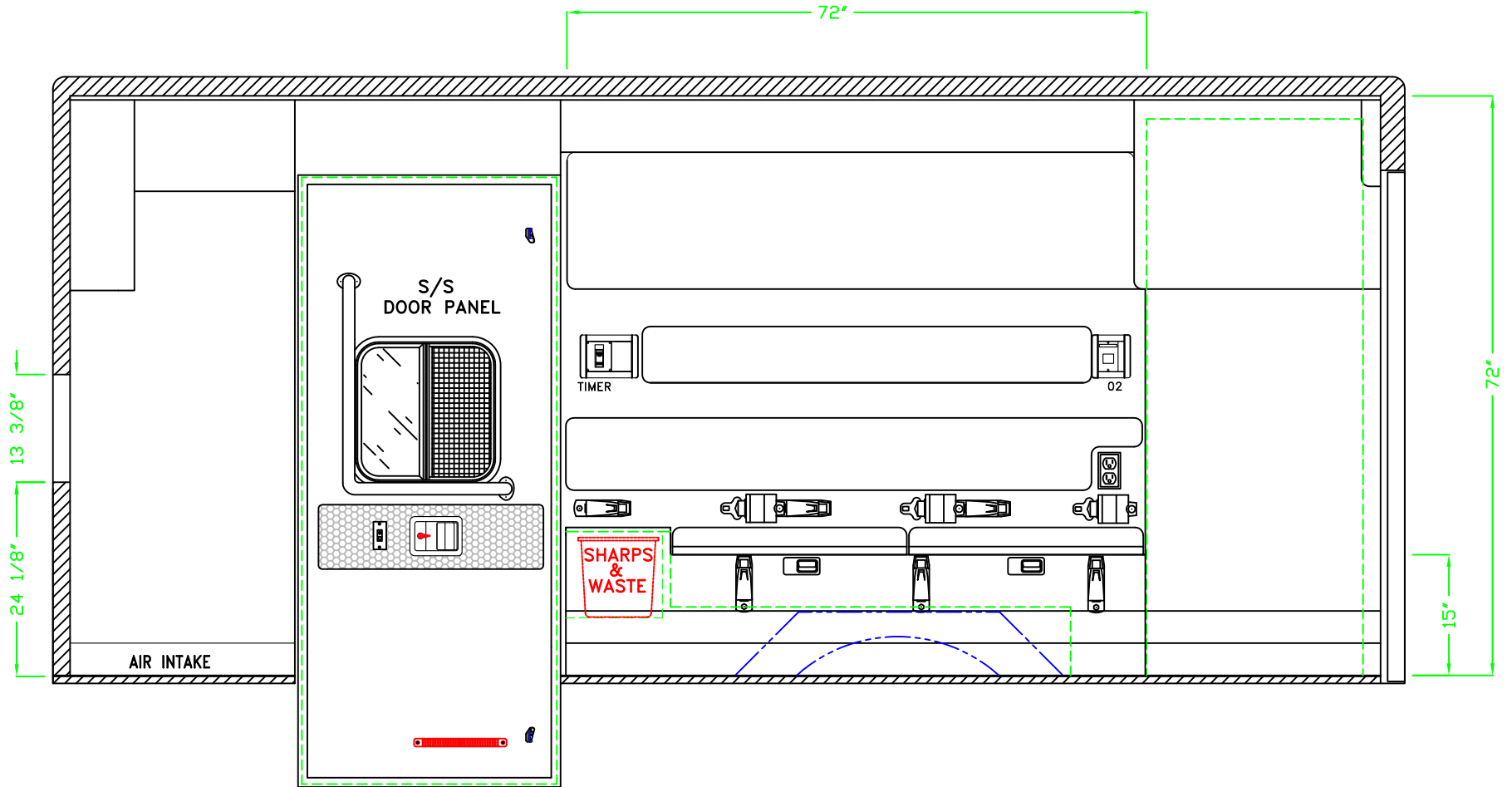

NOTES:

DETAILS ARE CONCEPTUAL ONLY.
 LAYOUT AND ALL DIMENSIONS ARE APPROXIMATE AND
 SUBJECT TO MODIFICATION BY DESIGN ENGINEERING.

PROPRIETARY AND
 CONFIDENTIAL
 THIS INFORMATION
 CONTAINED IN THIS
 DRAWING IS THE SOLE
 PROPERTY OF ROAD
 RESCUE ANY
 REPRODUCTION IN PART
 OR AS A WHOLE
 WITHOUT THE WRITTEN
 PERMISSION OF ROAD
 RESCUE IS PROHIBITED.

Road Rescue 2737 N. FORSYTH RD
 WINTER PARK, FL 32792
 www.roadrescue.com PHONE 800-932-7077 FAX 800-513-2688

CURBSIDE INTERIOR DETAIL

BID NUMBER

DRAWN BY RRS	DATE 04/15/2015	REVISION 1 05/12/2015	REVISION 2 05/14/2015	REVISION 3	SCALE	SHEET 5 OF 12
-----------------	--------------------	--------------------------	--------------------------	------------	-------	---------------

1R5195

NOTE: THIS DRAWING IS SUBJECT TO CHANGE PENDING ROAD RESCUE, INC. PRODUCTION ENGINEERING APPROVAL. © ROAD RESCUE, INC. ALL RIGHTS RESERVED.

F-450 4 X 4 ULTRAMEDIC PASS-THROUGH

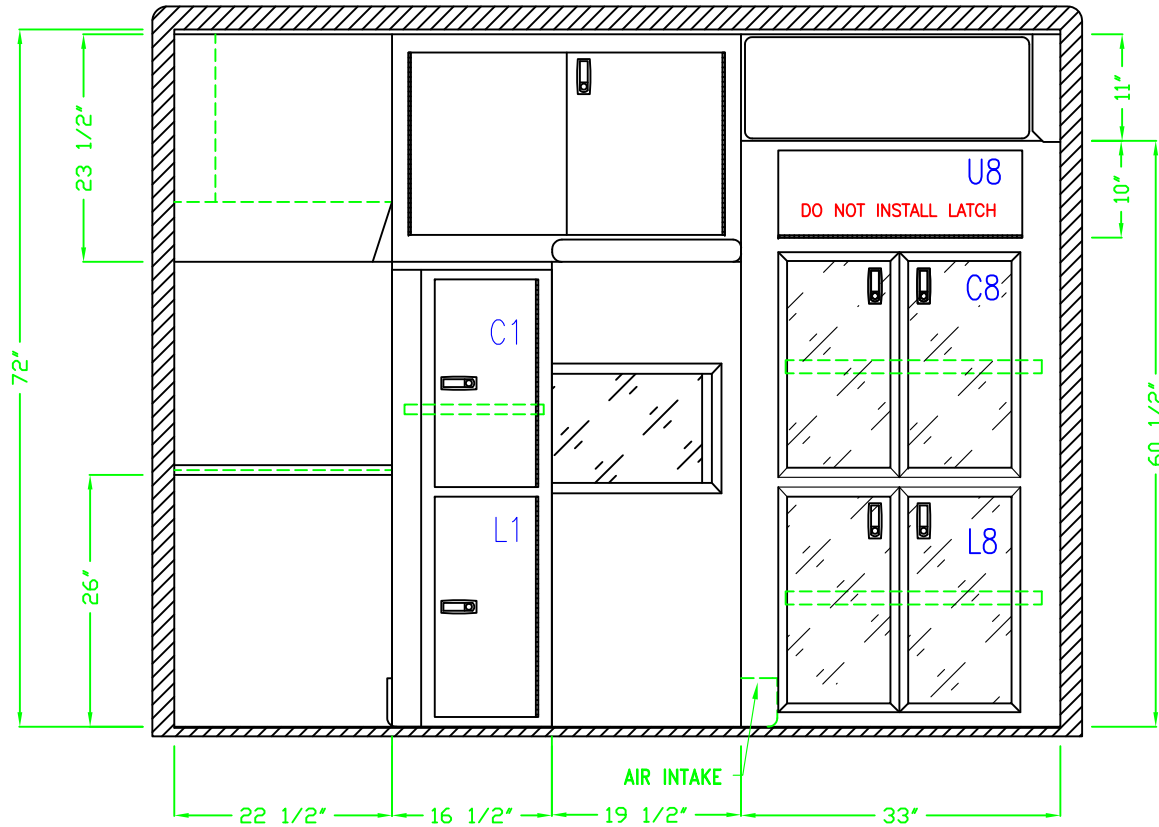

DOOR NO.	INTERIOR DIMENSIONS			NOTES
	HEIGHT	WIDTH	DEPTH	
U8	10.00"	25.00"	26.00"	SINGLE ALUM. DOOR, LOCKING LATCH
L8	25.00"	28.00"	26.00"	DOUBLE PLEX DOORS, (1) ADJ. SHELF
L8	25.00"	28.00"	26.00"	DOUBLE PLEX DOORS, (1) ADJ. SHELF

NOTES:

DETAILS ARE CONCEPTUAL ONLY.
LAYOUT AND ALL DIMENSIONS ARE APPROXIMATE AND
SUBJECT TO MODIFICATION BY DESIGN ENGINEERING.

PROPRIETARY AND CONFIDENTIAL
THIS INFORMATION CONTAINED IN THIS DRAWING IS THE SOLE PROPERTY OF ROAD RESCUE ANY REPRODUCTION IN PART OR AS A WHOLE WITHOUT THE WRITTEN PERMISSION OF ROAD RESCUE IS PROHIBITED.

FRONT INTERIOR DETAIL

F-450 4 X 4 ULTRAMEDIC PASS-THROUGH

DEALER SIGNATURE	QVM
------------------	-----

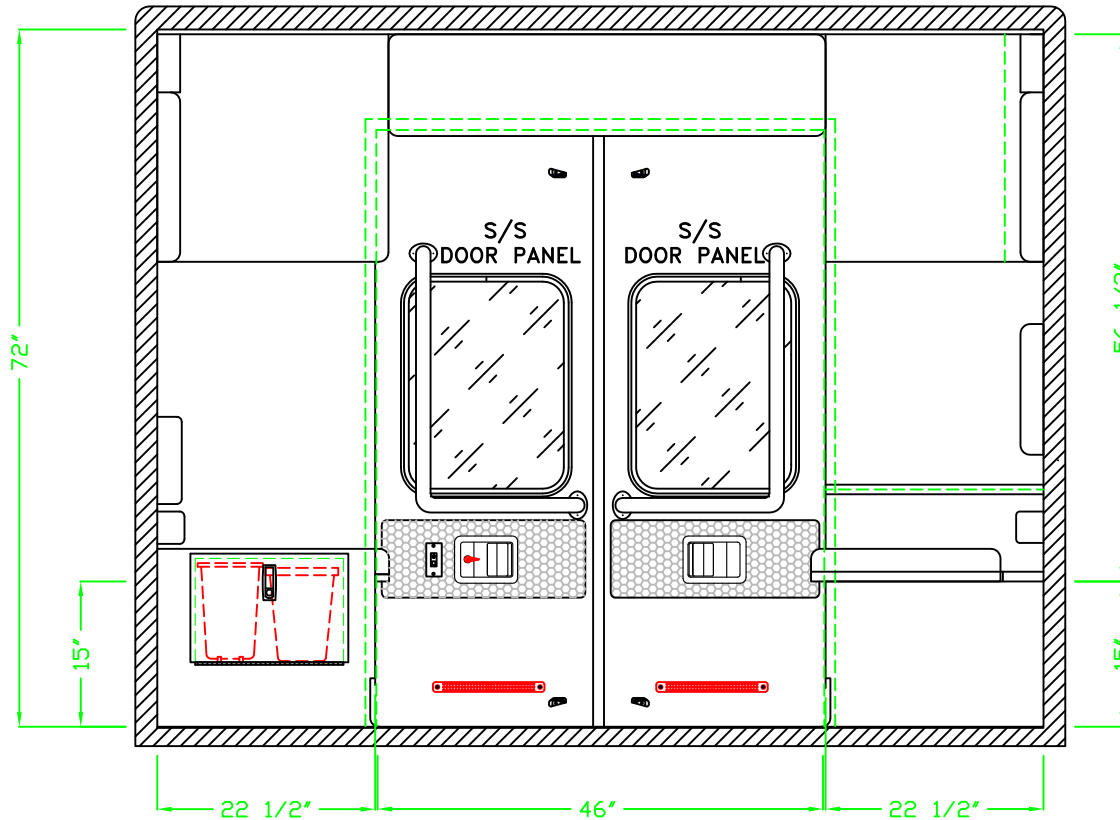

NOTES:

NOTES:

DETAILS ARE CONCEPTUAL ONLY.
LAYOUT AND ALL DIMENSIONS ARE APPROXIMATE AND
SUBJECT TO MODIFICATION BY DESIGN ENGINEERING.

PROPRIETARY AND
CONFIDENTIAL
THIS INFORMATION
CONTAINED IN THIS
DRAWING IS THE SOLE
PROPERTY OF ROAD
RESCUE ANY
REPRODUCTION IN PART
OR AS A WHOLE
WITHOUT THE WRITTEN
PERMISSION OF ROAD
RESCUE IS PROHIBITED.

Road Rescue



2737 N. FORSYTH RD
WINTER PARK, FL 32792

www.roadrescue.com PHONE 800-932-7077 FAX 800-513-2688

DRAWN BY RRS	DATE 04/15/2015	REVISION 1 05/12/2015	REVISION 2 05/14/2015	REVISION 3	SCALE
-----------------	--------------------	--------------------------	--------------------------	------------	-------

REAR INTERIOR DETAIL

BID NUMBER

 **1R5195** 

SHEET 7 OF 12



Road Rescue
AN ALLIED SPECIALTY VEHICLE COMPANY
In Service for Life™

F-450 4 X 4 ULTRAMEDIC PASS-THROUGH

DEALER SIGNATURE 

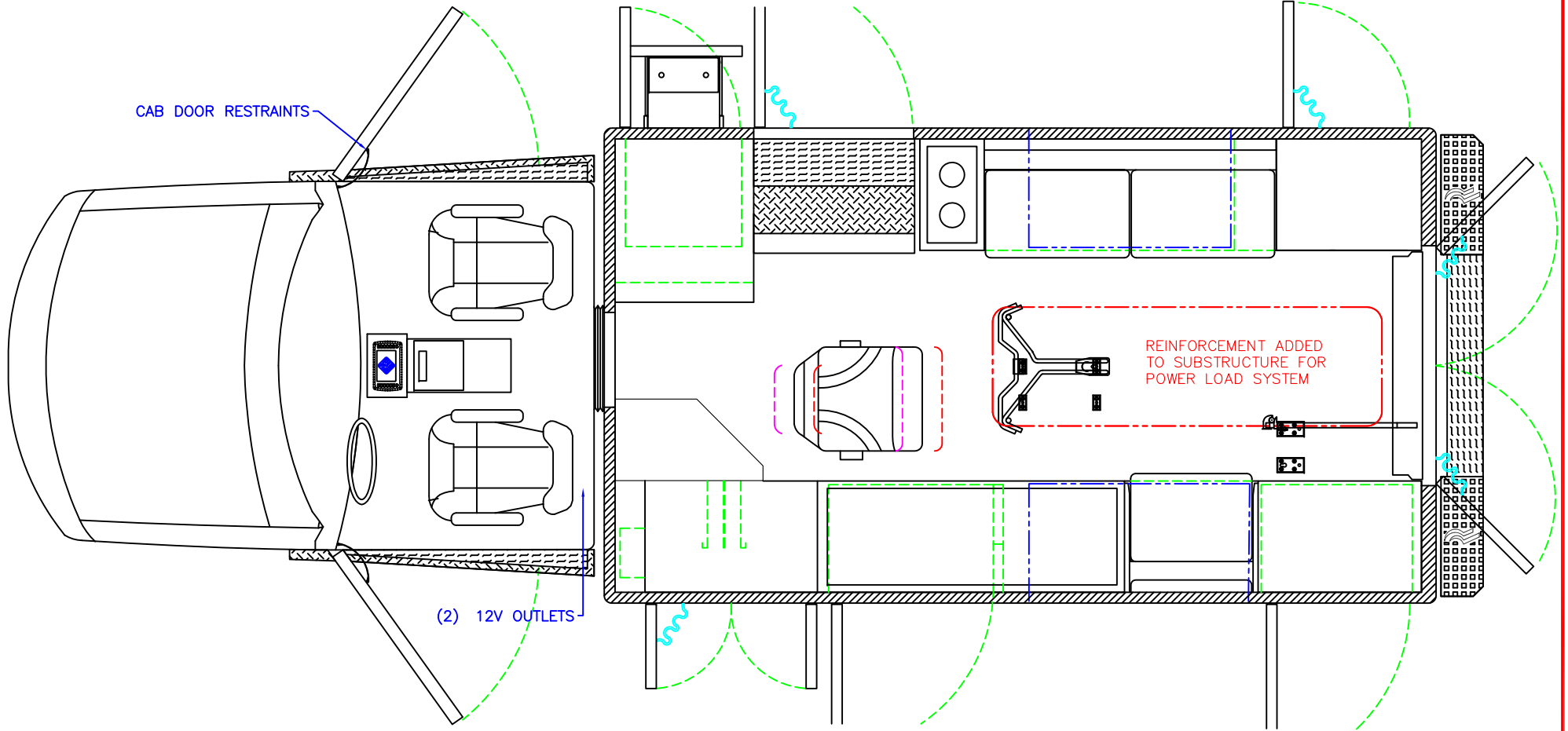

NOTES:



NOTES:

DETAILS ARE CONCEPTUAL ONLY.
LAYOUT AND ALL DIMENSIONS ARE APPROXIMATE AND
SUBJECT TO MODIFICATION BY DESIGN ENGINEERING.

PROPRIETARY AND
CONFIDENTIAL
THIS INFORMATION
CONTAINED IN THIS
DRAWING IS THE SOLE
PROPERTY OF ROAD
RESCUE ANY
REPRODUCTION IN PART
OR AS A WHOLE
WITHOUT THE WRITTEN
PERMISSION OF ROAD
RESCUE IS PROHIBITED.

Road Rescue 2737 N. FORSYTH RD
WINTER PARK, FL 32792
www.roadrescue.com PHONE 800-932-7077 FAX 800-513-2688

OVERHEAD FLOOR DETAIL

BID NUMBER
 **1R5195** 

DRAWN BY RRS	DATE 04/15/2015	REVISION 1 05/12/2015	REVISION 2 05/14/2015	REVISION 3	SCALE	SHEET 8 OF 12
-----------------	--------------------	--------------------------	--------------------------	------------	-------	---------------

NOTE: THIS DRAWING IS SUBJECT TO CHANGE PENDING ROAD RESCUE, INC. PRODUCTION ENGINEERING APPROVAL. © ROAD RESCUE, INC. ALL RIGHTS RESERVED.

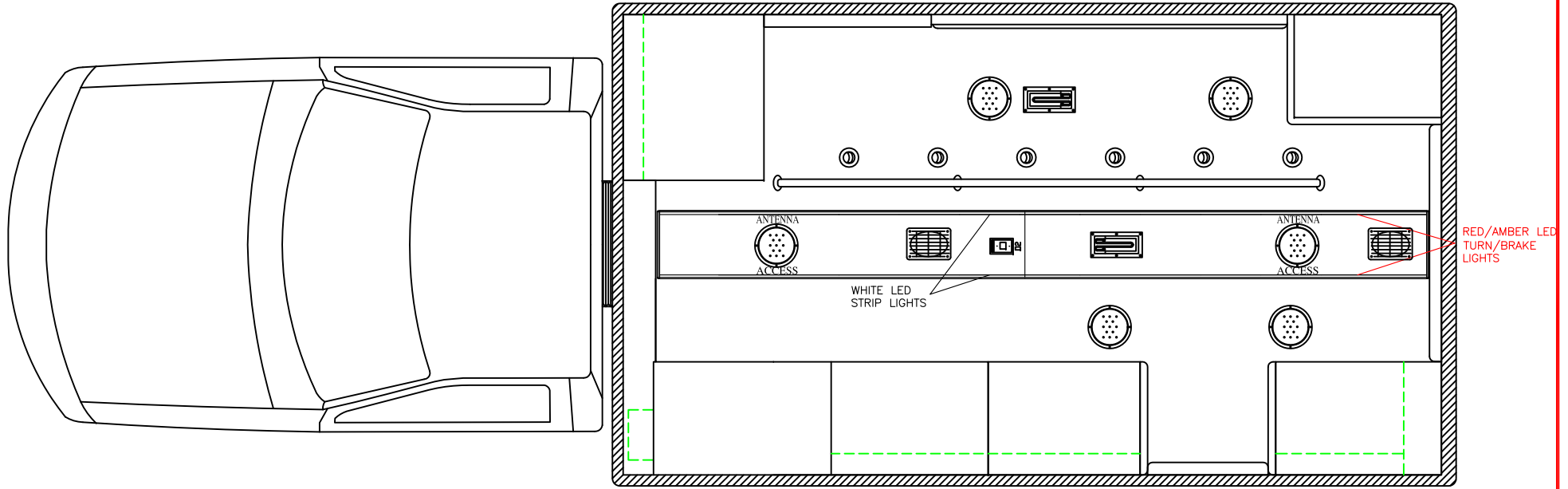

NOTES:

NOTES:

DETAILS ARE CONCEPTUAL ONLY.
LAYOUT AND ALL DIMENSIONS ARE APPROXIMATE AND
SUBJECT TO MODIFICATION BY DESIGN ENGINEERING.



PROPRIETARY AND
CONFIDENTIAL
THIS INFORMATION
CONTAINED IN THIS
DRAWING IS THE SOLE
PROPERTY OF ROAD
RESCUE ANY
REPRODUCTION IN PART
OR AS A WHOLE
WITHOUT THE WRITTEN
PERMISSION OF ROAD
RESCUE IS PROHIBITED.

Road Rescue 2737 N. FORSYTH RD
WINTER PARK, FL 32792
www.roadrescue.com PHONE 800-932-7077 FAX 800-513-2688

OVERHEAD CEILING DETAIL

BID NUMBER

DRAWN BY RRS	DATE 04/15/2015	REVISION 1 05/12/2015	REVISION 2 05/14/2015	REVISION 3	SCALE	SHEET 9 OF 12
-----------------	--------------------	--------------------------	--------------------------	------------	-------	---------------

 **1R5195** 

F-450 4 X 4 ULTRAMEDIC PASS-THROUGH

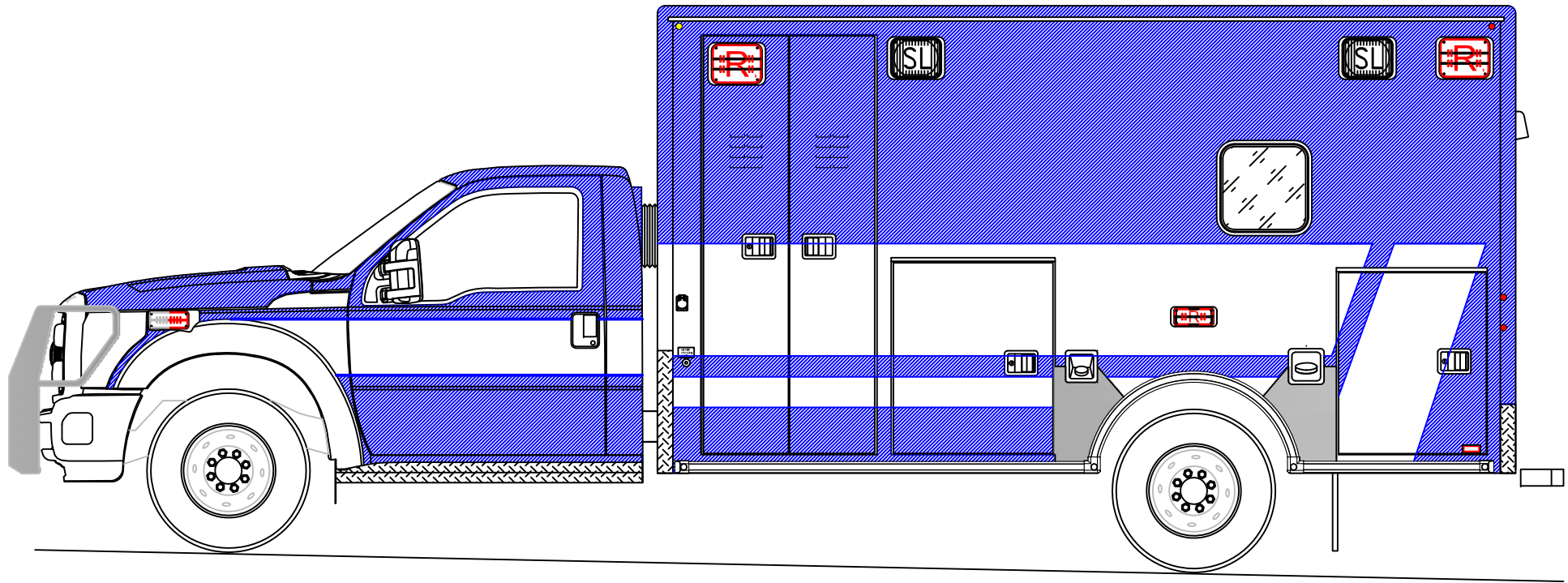

DETAILS ARE CONCEPTUAL ONLY.
LAYOUT AND ALL DIMENSIONS ARE APPROXIMATE AND
SUBJECT TO MODIFICATION BY DESIGN ENGINEERING.

PROPRIETARY AND
CONFIDENTIAL
THIS INFORMATION
CONTAINED IN THIS
DRAWING IS THE SOLE
PROPERTY OF ROAD
RESCUE ANY
REPRODUCTION IN PART
OR AS A WHOLE
WITHOUT THE WRITTEN
PERMISSION OF ROAD
RESCUE IS PROHIBITED.



Road Rescue 2737 N. FORSYTH RD
WINTER PARK, FL 32792
www.roadrescue.com PHONE 800-932-7077 FAX 800-513-2688

STREETSIDE GRAPHICS

BID NUMBER

DRAWN BY RRS	DATE 04/15/2015	REVISION 1 05/12/2015	REVISION 2 05/14/2015	REVISION 3	SCALE
-----------------	--------------------	--------------------------	--------------------------	------------	-------

SHEET 10 OF 12

 **1R5195** 



Road Rescue
AN ALLIED SPECIALTY VEHICLE COMPANY
In Service for Life

F-450 4 X 4 ULTRAMEDIC PASS-THROUGH

DEALER SIGNATURE	

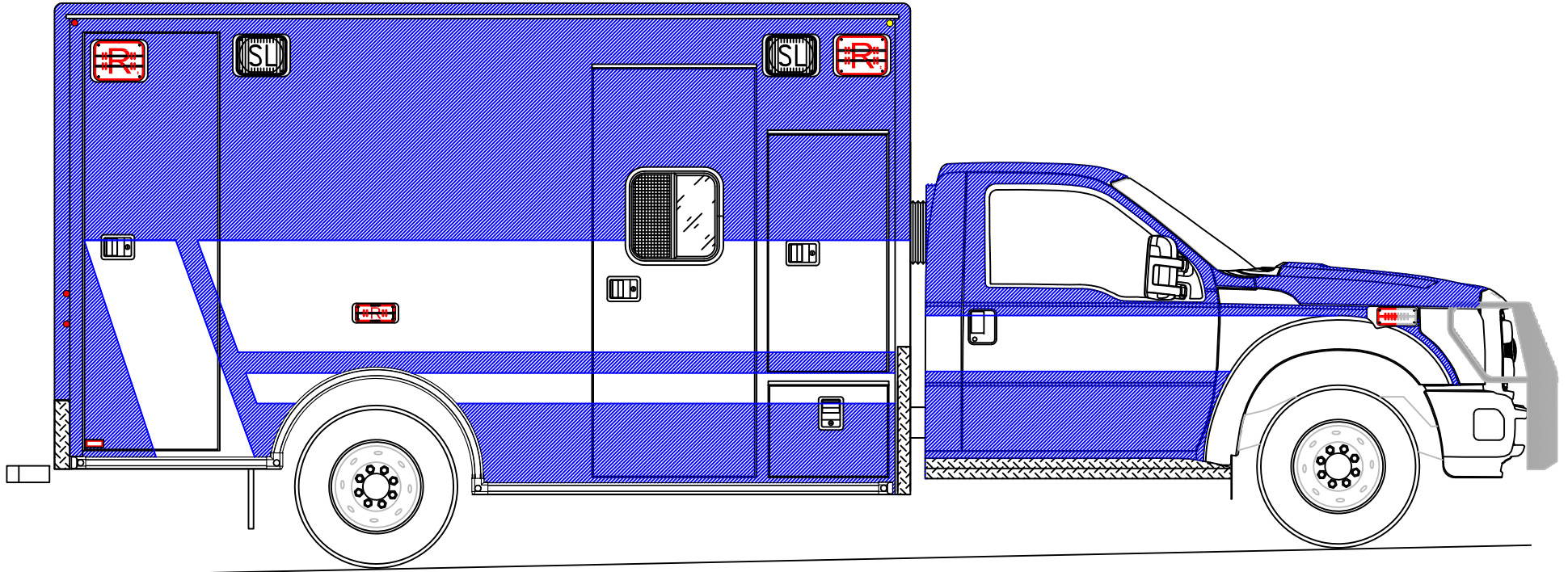

DETAILS ARE CONCEPTUAL ONLY.
 LAYOUT AND ALL DIMENSIONS ARE APPROXIMATE AND
 SUBJECT TO MODIFICATION BY DESIGN ENGINEERING.

PROPRIETARY AND
 CONFIDENTIAL
 THIS INFORMATION
 CONTAINED IN THIS
 DRAWING IS THE SOLE
 PROPERTY OF ROAD
 RESCUE ANY
 REPRODUCTION IN PART
 OR AS A WHOLE
 WITHOUT THE WRITTEN
 PERMISSION OF ROAD
 RESCUE IS PROHIBITED.

Road Rescue 2737 N. FORSYTH RD
 WINTER PARK, FL 32792
 www.roadrescue.com PHONE 800-932-7077 FAX 800-513-2688

CURBSIDE GRAPHICS

BID NUMBER

DRAWN BY RRS	DATE 04/15/2015	REVISION 1 05/12/2015	REVISION 2 05/14/2015	REVISION 3	SCALE
-----------------	--------------------	--------------------------	--------------------------	------------	-------

SHEET 11 OF 12

1R5195

F-450 4 X 4 ULTRAMEDIC PASS-THROUGH

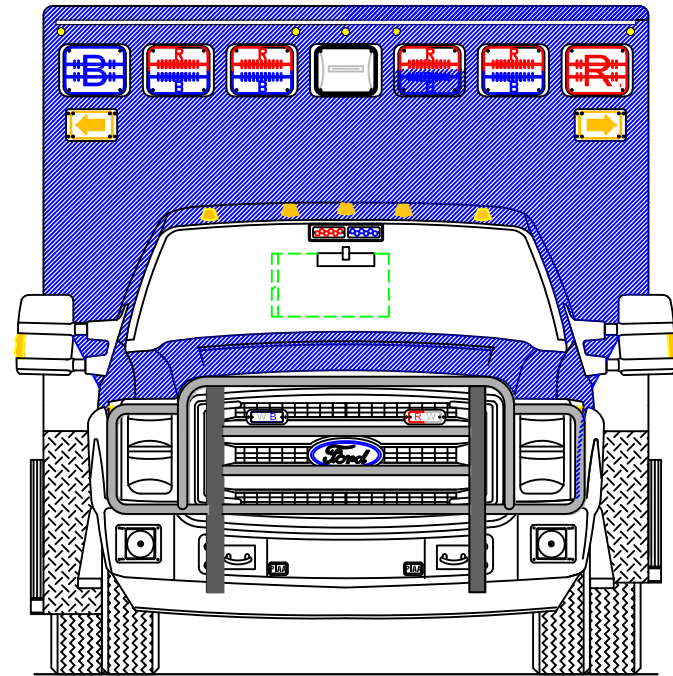
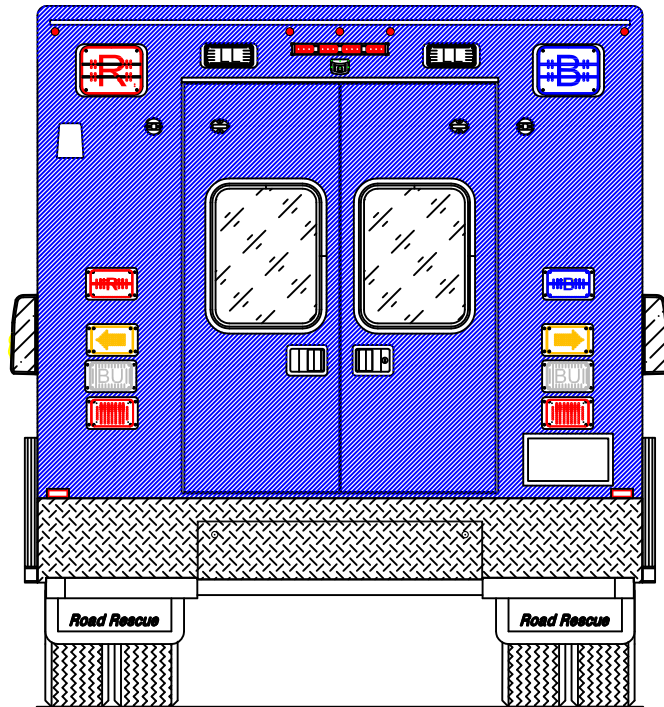

DETAILS ARE CONCEPTUAL ONLY.
LAYOUT AND ALL DIMENSIONS ARE APPROXIMATE AND
SUBJECT TO MODIFICATION BY DESIGN ENGINEERING.

PROPRIETARY AND
CONFIDENTIAL
THIS INFORMATION
CONTAINED IN THIS
DRAWING IS THE SOLE
PROPERTY OF ROAD
RESCUE ANY
REPRODUCTION IN PART
OR AS A WHOLE
WITHOUT THE WRITTEN
PERMISSION OF ROAD
RESCUE IS PROHIBITED.



Road Rescue 2737 N. FORSYTH RD
WINTER PARK, FL 32792
www.roadrescue.com PHONE 800-932-7077 FAX 800-513-2688

FRONT & REAR GRAPHICS

BID NUMBER

DRAWN BY RRS	DATE 04/15/2015	REVISION 1 05/12/2015	REVISION 2 05/14/2015	REVISION 3	SCALE
-----------------	--------------------	--------------------------	--------------------------	------------	-------

SHEET 12 OF 12

 **1R5195** 

WILLMAR AMBULANCE SERVICE F-450 ULTRAMEDIC // PASS-THROUGH

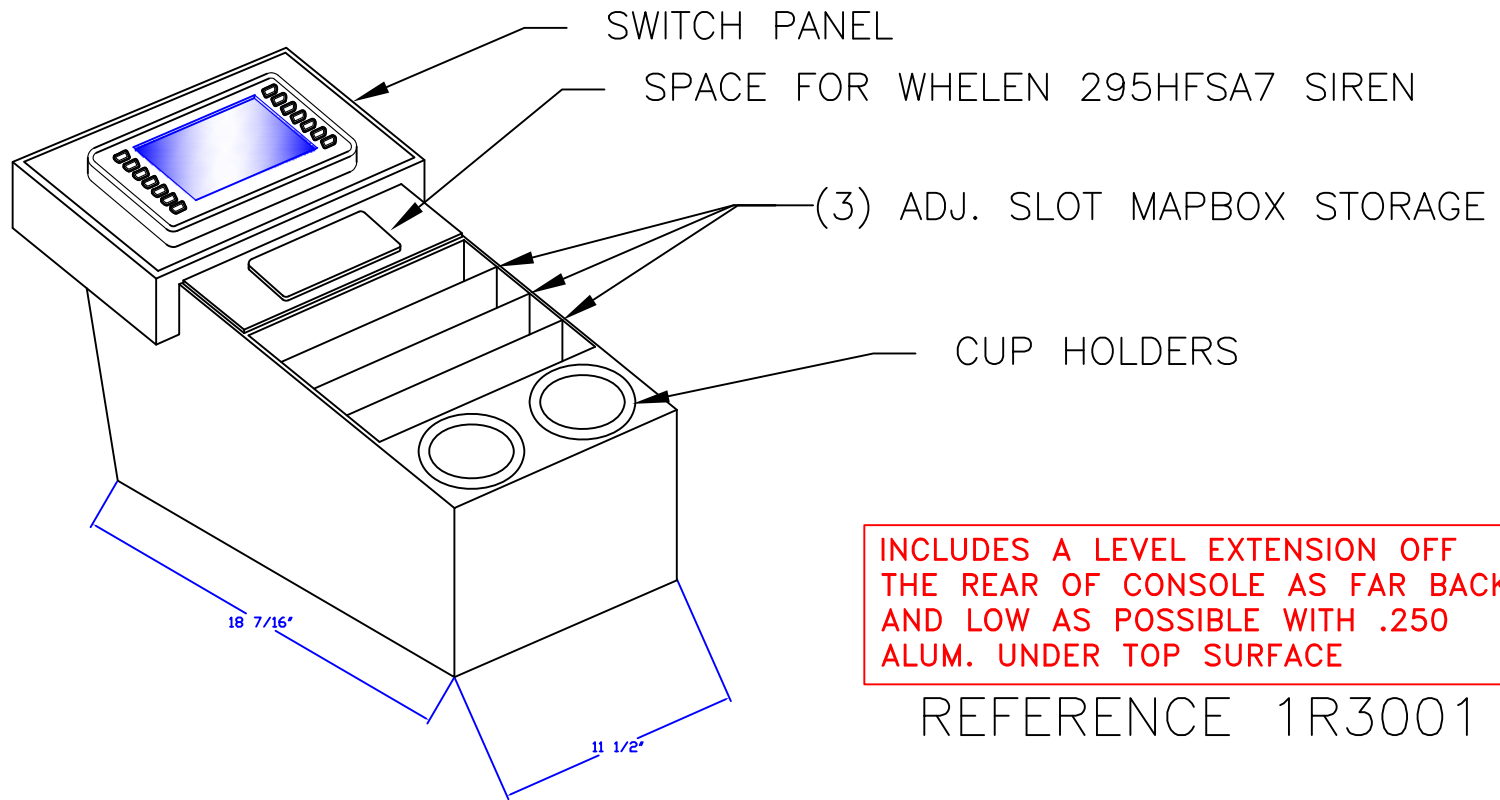

INCLUDES A LEVEL EXTENSION OFF THE REAR OF CONSOLE AS FAR BACK AND LOW AS POSSIBLE WITH .250 ALUM. UNDER TOP SURFACE

REFERENCE 1R3001

PROPRIETARY AND CONFIDENTIAL
THIS INFORMATION CONTAINED IN THIS DRAWING IS THE SOLE PROPERTY OF ROAD RESCUE INC. ANY REPRODUCTION IN PART OR AS A WHOLE WITHOUT THE WRITTEN PERMISSION OF ROAD RESCUE IS PROHIBITED.

DETAILS ARE CONCEPTUAL ONLY. LAYOUT AND ALL DIMENSIONS ARE APPROXIMATE AND SUBJECT TO MODIFICATION BY DESIGN ENGINEERING.

Road Rescue <small>2737 N. FORSYTH ROAD WINTER PARK, FL 32792</small> <small>www.roadrescue.com PHONE 800-932-7077 FAX 800-513-2688</small>		CONSOLE CONFIGURATION				BID NUMBER
		SCALE NONE	SHEET 1 OF 1	1R5195		
DRAWN BY	DATE	REVISION 1	REVISION 2	REVISION 3		